



*An Online CPD Course  
brought to you by  
CEDengineering.ca*

# HVAC Cooling Systems for Data Centers

Course No: M05-020  
Credit: 5 PDH

---

A. Bhatia

---



Continuing Education and Development, Inc.

P: (877) 322-5800  
[info@cedengineering.ca](mailto:info@cedengineering.ca)

[www.cedengineering.ca](http://www.cedengineering.ca)

## **HVAC COOLING SYSTEMS FOR DATA CENTERS**

### **Abstract**

Air-conditioning systems for data centers are designed for year-round cooling with very high cooling intensity per square foot of floor area. The high sensitivity of electronic components in such facilities requires that temperature, humidity, air movement and air cleanliness must be kept consistent and within specific limits to prevent premature equipment failures and costly downtime.

Because data centers are high-density enclosed spaces that generate a significant amount of heat, traditional comfort cooling systems can't remove enough heat to protect the critical equipment. Instead, these unique areas require dedicated units with precision cooling capabilities. In a typical data center environment for example; the heat densities can be up to five times higher than in a typical office setting. To illustrate, one ton of comfort cooling capacity (12,000 BTU/hour, or 3,517 W) is required per 250 to 300 square feet of office space. This translates into 12 to 14 watts per square foot. In contrast, one ton of precision cooling capacity is required per 50 to 100 square feet of data center space, which translates to 35 to 70 watts per square foot on average. New data centers today have load densities as high as 200 to 300 watts per square foot. From an airflow standpoint, precision cooling equipment typically supply between 500 and 900 cubic feet per minute (CFM) per cooling ton. This contrasts with the much smaller range of 350 to 400 CFM per cooling ton typically delivered by comfort cooling equipment.

This course presents some of the basic fundamental concepts governing the design of air conditioning systems in today's data centers. The course is divided into 5 sections:

- Section - 1:           OVERVIEW OF A DATA CENTER
- Section - 2:           HVAC COOLING SYSTEM DESIGN
- Section - 3:           DATA CENTER HVAC EQUIPMENT
- Section - 4:           DATA CENTER AIR DISTRIBUTION
- Section - 5:           COOLING PERFORMANCE AND EFFICIENCY

**SECTION - 1: OVERVIEW OF A DATA CENTER**

Data centers (also referred to as server rooms or IT rooms) are the building blocks of any business organization providing capabilities of centralized storage, backups, management, networking and dissemination of data. Data centers fall into two major categories: corporate data centers (CDCs) and Internet data centers (IDCs).

Corporate data centers are owned and operated by private organizations, institutions or government agencies that are critically dependent upon information and communication technology systems. Their prime purpose is to support data processing and web-oriented services for their self-use.

Internet data centers are primarily owned and operated by third party service providers or by commercial operators. Their primary objective is to provide IT services to their clients and the customers on rent with or without IT hardware while sharing common power, cooling and facilities infrastructure. The services may include but are not limited to wide-area communications, fast and reliable internet access, web or application hosting, server rent out, back-up storage facilities, content distribution and load sharing with new variations appearing almost daily. This kind of facility benefits large companies like banking, stock exchanges, travel, insurance and other service providers who need back-up servers for business operations and to cover business risks. Small and medium scale companies also benefit, both monetary and ensuring goodwill.

Data centers can easily be recognized by equipment racks that contain servers, storage devices, network cabling and equipment. The most critical of these elements are the rack structures housing IT equipment. Another critical part of a data center architecture is the utility infrastructure like power supplies, air conditioning, fire suppression and other security devices. There are three functional requirements of a data center:

1. Data center space planning for locating servers, storage and network devices
2. Electric supplies and network connectivity provided to other devices both inside and out.
3. Temperature/Humidity control environment within the parameters needed.

## **DATA CENTER SPACE PLANNING AND DESIGN**

When determining the location and design of the data center, consider the following issues:

1. **Moisture and air leakage** - Ensure that the data center is not located below any room that could cause water or moisture to leak into the data center. Exclude plumbing from the room, except plumbing that supports the fire suppression and heating, ventilation, and air conditioning (HVAC) systems. To prevent air and moisture leakage, do not install windows that open to the outside of the facility.
2. **Contaminants** - Isolate the data center from activities that could contaminate the environment. Ensure that the air intake for the data center is clean. Maintain airborne dusts, gasses, and vapors within defined limits for data center environments to minimize their impact on the systems. Ideally it is preferred that a data center is made as a room in the room, meaning that none of the walls are part of the outer facade of the building.
3. **Access** - Ensure that there is adequate access to the data center from the loading dock, freight elevator, or other equipment entrances.
4. **Security** - Provide secure points of entry to the data center so that only the proper personnel have access to the equipment. Equip data center doors with secure locking mechanisms that can remain operational during a power failure.
5. **Room temperature and humidity** - Ensure that the data center has the required air conditioning equipment to adequately cool the systems. Install an automatic alarm system to notify personnel if temperature or humidity exceeds the specified thresholds.
6. **Airflow** - Consider the intake and exhaust airflow of the systems and ensure that the airflow in the room facilitates cooling of equipment.
7. **Raised flooring** - Design the raised flooring to maximize access and to support equipment and cables.
8. **Ceiling height** – Ensure adequate ceiling height to accommodate a 7-foot equipment rack.

9. Aisle space - Provide adequate room at the front and back of cabinets and racks to allow unobstructed servicing of the systems and clear passage for personnel. Keep minimum 48" in the front and 36" on the rear.
10. Expansion room - Design the data center in a way that can accommodate future equipment expansion. Include resources that can provide additional power, environmental support, and floor usage.

### **ELECTRIC SUPPLIES AND NETWORK CONNECTIVITY**

The design of an electrical power system must ensure that adequate, high-quality power is provided to each server, air conditioning and all peripherals at all times. The need to minimize feeder lengths is a primary consideration when developing the space plan for the data center power system.

The power infrastructure must be designed to provide sufficient redundancy, eliminate all single points of failure, and allow the isolation of a single system for testing or maintenance without affecting the power supplied to other systems. It is important to secure multiple sources of power when possible. It is prudent to attach to each primary power supply a common power cord from one power grid that can supply power to all systems, and to attach another power cord from a different power grid to the redundant supplies. If a primary power grid goes offline, a backup power grid will provide power to the redundant supplies to keep the systems operating.

### **Estimated Power Requirements**

A convenient measure of the data center power density is watts per square feet (WPSF) of floor area. Current industry practices estimate power requirements at an average of 50 to 150 WPSF, but as the servers and storage systems become ever more powerful and compact, they place a greater strain on the facility to deliver more power, reject more heat and maintain adequate backup power reserves (both battery backup and onsite power generation). In addition, more power requirements for the HVAC system will become necessary. A standard practice is to add 70% to the total IT equipment power needs.

### **Quality of Power**

The electronic equipment is extremely sensitive to power interruptions or fluctuations. These electrical impurities can disrupt and even ruin sensitive electronic equipment. Surge arresters and line interactive systems often provide enough power conditioning for servers and should be included as part of the electrical system.

### **Emergency Power**

Using an online uninterruptible power supply (UPS) and a backup power generator provides a good strategy for obtaining an uninterruptible source of power. The online UPS filters, conditions and regulates the power. It protects the systems from fluctuating voltages, surges and spikes, as well as noise that may be on the power line. The battery backup for the UPS should be capable of maintaining the critical load of the data center for a minimum of 15 minutes during a power failure. This is typically sufficient time to transfer power to an alternate feed or to the power generator.

The backup power generator should be able to carry the power requirements of the IT equipment, HVAC and essential auxiliaries. The generator should include dual power distribution switch gear with automatic transfer switching. To offset the possibility of a generator failure, power system designers often include a temporary generator for secondary backup.

### **Grounding**

Grounding design must address both the electrical service and the installed equipment. A properly designed grounding system should have as low an impedance as is practically achievable for proper operation of electronic devices as well as for safety. It is important to use a continuous, dedicated ground for the entire power system to avoid a ground differential between various grounds. Grounding design in the United States should comply with Article 250 of the U.S. National Electrical Code unless superseded by local codes. Use an antistatic wrist strap when working inside the chassis.

### **Physical security and fire protection**

According to National Fire Protection Association, NFPA 75, “Standard for the Protection of Electronic Computer/Data Processing Equipment”, an emergency power off switch must be placed at every point of entry to the data center, which shall isolate power to

every computer system, UPS and HVAC. It must be clearly labeled and unobstructed. An inert gas like FM 100 or argon should be used as fire suppression agent. Always have a smoke detector along with an alarm.

### **Emergency Power Control**

A primary power switch that can disconnect all electronic equipment in the data center is specified by NFPA 70 and NFPA 75 (National Fire Protection Association specifications) at each point of entry to the data center. The primary switch should disconnect power to all computer systems and related electronic equipment, HVAC equipment, UPS, and batteries. Multiple disconnects for separate parts of the power systems are also acceptable, but in both cases, the switches must be unobstructed and clearly marked.

### **HVAC – TEMPERATURE AND HUMIDITY CONTROL**

The data center equipment generates a considerable amount of heat in a relatively small area. This is because every watt of power used by a system is dissipated into the air as heat. Unless the heat is removed, the ambient temperature will rise, eventually beyond design specifications resulting in electronic equipment failure.

The HVAC system for the data center is managed by the air conditioning system, which is influenced by 5 main factors:

1. The type of IT equipment
2. The IT equipment configuration
3. The “service levels”
4. The budget and
5. The ‘Green Policy’

Let’s examine each of the factors:

#### **The IT Equipment**

The type of IT equipment has a huge bearing on the choice of cooling infrastructure. Two types of servers are common: 1) rack-mount servers, and 2) blade servers.

1. **Rack-mounted:** Rack-mounted servers are contained in a horizontal case “1U to 5U” in height. ‘U’ is a measurement of rack height that equals 1.75” (44.45 mm).

The benefits of rack servers are that they offer an efficient use of floor space, and easier management of cables and servers. A rack server cabinet offers the flexibility to use servers from different manufacturers.

2. **Blade Servers:** Blade servers are plug-and-play processing units with shared power feeds, power supplies, fans, cabling and storage. By compressing large amounts of computing capacity into small amounts of space, blade servers can dramatically reduce data center floor space requirements. In these systems, you may have eight servers in one 5U case. Unfortunately, they can also raise power densities above 15 kW per rack, dramatically increasing data center heat levels.

Both servers have their advantages and limitations.

Blade servers use less space. Multiple servers can be accommodated in a consolidated space, and communication is simple. For example, if the blade server in slot 1 needs to communicate to the blade server in slot 6, the communication never leaves the chassis. The two servers can communicate at line speed. Compared to a rack server environment, the communications would have to travel to the top of rack or edge network device before it can travel back. Blade servers share the same space, cooling, power and connectivity. Sharing of resources means utilizing your power and cooling elements more efficiently.

Although blade servers have their benefits, the general perception is that blade servers don't fit everywhere. Rack servers provide more flexibility in a sense that these can hold more memory, more CPUs and more I/O as well as use the same chipsets as blade servers. Studies indicate that if you are not running out of power and cooling; you don't have space constraints; you need a lot of local I/O expansion; or you don't have management issues with your physical server environment, you may be better off with rack servers.

Per current trends, the rack-mounted servers appeal to larger organizations, while blade servers are more popular with small- to medium-sized businesses. The selection however should be left to the specialists.



## The IT Equipment Configuration & Layout

The flow of air through the servers is important for effective heat dissipation. It is affected by many variables, including the cabinet and door construction, cabinet size, and thermal dissipation of any other components within the cabinet. Problems sometimes arise for these reasons:

- One server is positioned so that its hot exhaust air is directed into the intake air of another server, thus preheating the intake air of the second server.
- Servers are sometimes mounted in cabinets that restrict airflow excessively. This might occur because the cabinets have inadequate openings on the front and back doors or inadequate clearances between the equipment and the doors of the cabinets. The servers require that the front and back cabinet doors to be at least 63% open for adequate airflow. In addition, a minimum of 1.5-inch clearance between the systems and front and back doors of a cabinet should be maintained.
- A server might be mounted in a cabinet above a device that generates a great amount of heat.

HVAC equipment location and system design is also important. ASHRAE recommends laying out equipment racks according to the Hot Aisle–Cold Aisle layout, which means aligning IT equipment racks in rows, such that the cabinet fronts face the cool aisle, and exhaust is directed to the hot aisle. This type of design minimizes hot and cold air mixing and maximizes the heat dissipation. See the figure below.

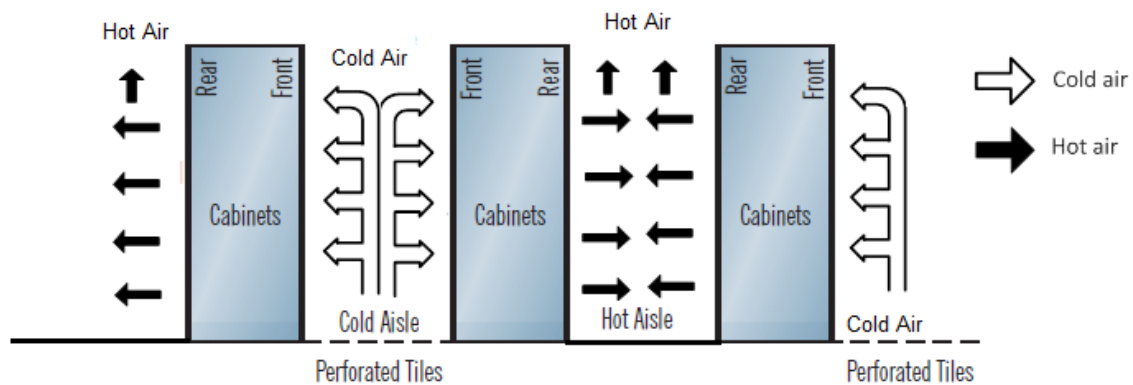

According to the recent ANSI/TIA/EIA-942 data center standard, a minimum of 4 feet (equivalent to two floor tiles) front clearance must be provided for installation of equipment. A minimum of 2 feet rear clearance must be provided for service access. A 3-foot rear clearance is recommended.

### Cooling Systems

The most common design configuration is the underfloor supply system that relies on a raised floor with air conditioning equipment's (CRAC units) located around the perimeter of the room. This model has the following functionalities:

- CRAC units pump cold air into the floor void.
- Vents in the floor deliver cold air to the front of the racks facing each other (cold aisle).
- Hot air escapes through the back of the rack into the hot aisle where it returns the air to the CRAC unit.

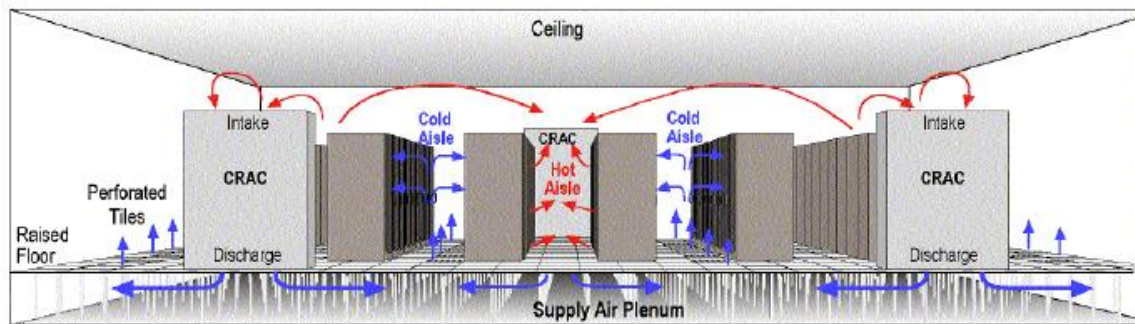

### Cooling System with Raised Floor Configuration (hot aisle/cold aisle layout)

(Figure Source: HP)

The placement of racks is very important. If you set up your room in the wrong layout, i.e. all racks facing the same direction, the hot air from the back of one rack will be sucked into the front of the racks in the next row, causing it to overheat and eventually fail.

Temperature and humidity sensors should be installed to monitor the temperature and humidity of the server room or data center to prevent server damage.

## In-Row Cooling

In-row cooling utilizes cooling units to be mounted directly within the rows of racks between cabinets. This configuration ensures localized cooling directly to the front of each rack and provides a very high heat dissipation capability. When used in conjunction with containment systems, this arrangement is capable of providing at least 20 kW to 30 kW of cooling per cabinet.

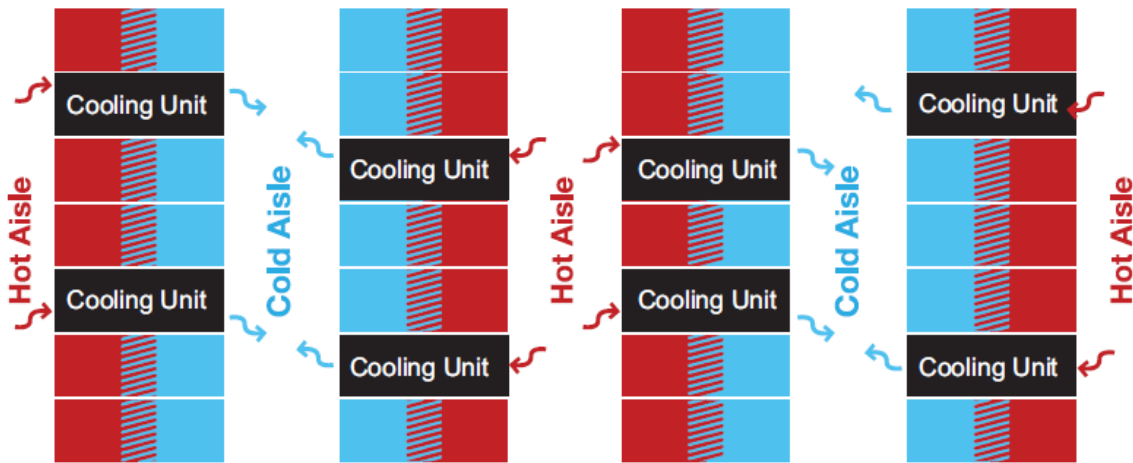

The “In-Row” solutions certainly have their justifications when used in the specific applications for which they were conceived, but they have certain disadvantages:

- Reduced reliability due to a number of potential failure points.
- Access to a cooling unit is limited due to its location between cabinets.
- Units consume valuable floor space, typically consuming a third of the width of a cabinet.

The energy efficiency characteristics of in-row cooling are not documented and have potentially higher maintenance costs than traditional CRAC for data centers. In this course we will focus on the hot aisle-cold aisle layout.

## The Service Levels - How Critical is the Data Center

Since data centers operate 24 hours a day and 365 days a year, the cooling system must be designed to accommodate continuous heat extraction and consider redundancy into the design to continue the facility’s operation during a failure event. However, it is

important to get the level of redundancy correct for the business to ensure that it is effective, but not excessive.

Provisions for servicing and maintenance should be included in the design phase of the project. These provisions should include:

- Selection of equipment with a view for durability, reliability and maintainability;
- Openings for the largest size component to be delivered and installed;
- Uninterrupted access to all HVAC components requiring servicing;
- Local availability of components and stock of all long lead items; and
- Local servicing personnel trained and qualified by the computer room A/C unit manufacturer.

The design of the facility will be largely based on business requirements for system resilience and reliability.

### **The Budget/Cost of a Cooling Source**

Is the data center cooled using direct expansion (DX) units or chilled water? As with all things the budget often will dictate the cooling solution adopted.

Direct expansion (DX) systems comprise individual compressors within each of the air distribution units in the data center. The coefficient of performance (CoP) for these systems ranges between 2.5 and 4, but are generally less expensive for initial installation costs.

Chilled-water systems offer very high energy efficiency and can operate with a CoP greater than 7. These also allow for excellent part load efficiencies. However, they are a far more expensive option compared to DX.

From an OPEX point of view, the chilled water option is much more cost-effective. From CAPEX point of view, the DX solution will often be the recommended option, unless you just physically don't have enough space to fit all the IT into the available space.

### Legends

- DX – Direct expansion refrigeration system

- OPEX – Operational expenditure (operational cost for energy and maintenance)
- CAPEX – Capital expenditure (initial cost of supply and installation)

### **The ‘Green Policy’**

The data center is a big consumer of energy both for driving the IT equipment and also for the cooling system. The energy bill for the data center is often the major part of the overall operating costs and is increasingly a visible part of the IT delivery cost. While the energy consumed by data-processing equipment is fairly constant year-round, considerable inefficiencies are attributed to cooling systems. Some of the inefficiencies are:

- Air conditioning units work at full capacity all of the time;
- Cooling equipment is not aligned for air flow direction within racks and the temperatures vary greatly throughout the room; and
- The level of cold supply air remix with hot return air is usually very high, producing very poor air conditioning efficiency.

Reducing the energy consumption of a data center is, unfortunately, not as simple as just turning up the thermostat to reduce the work for the cooling system. There is a distinct sequence to the actions to ensure that the efficiency improvement is actually realized and that reliability is not compromised in the process. Simple steps that can achieve more efficient cooling and lower the power consumption include:

- Organize server racks into a hot and cold aisle configuration. Install racks to achieve a front-to-back airflow pattern that draws conditioned air in from cold aisles located in front of the equipment, and rejects heat out through the hot aisles behind the racks.
- Buy servers and HVAC equipment that meet Energy Star efficiency requirements.
- Group IT equipment with similar heat load densities and temperature requirements together. Isolating equipment by the environmental requirements of temperature and humidity allows cooling systems to be controlled to the least energy-intensive set points for each location.

- Consolidate IT system redundancies. Consider one power supply per server rack instead of providing power supplies for each server. For a given redundancy level, integrated rack mounted power supplies will operate at a higher load factor (potentially 70%) compared to the individual server power supplies (20% to 25%). This increase in power supply load factor vastly improves the power supply efficiency.
- Implement curtains and ducting for absolute separation of hot and cold air, thereby preventing any short circuiting.
- Manage cables and penetrations: 1) bunch cables together using ties, and 2) install brushes or place pillows over any penetrations within the raised floor.
- Minimize lighting levels and install sensors.
- Instigate systematic management of site and faults and monitor power and cooling trends.
- Solar heat gains through windows should be eliminated by enclosing any existing windows with an insulated barrier. Additionally, any gaps that allow unnecessary infiltration/exfiltration need to be sealed and eliminated.
- Eliminate unnecessary infiltration by sealing any gaps in the walls and floor.
- Implement free cooling technology to utilize low ambient temperature and humidity conditions.
- Conduct a CFD Survey. This will identify exactly how well your cooling system is performing and will show how changes can be made to optimize the system.

A 50 to 100% increase cooling efficiency, corresponding to a 30 to 50% reduction in the cooling energy cost, can be achieved with a ~40 to 400% annual return on investment (ROI) using energy efficient technology and measures. More energy efficiency opportunities are highlighted in subsequent sections.

## **SECTION - 2: HVAC COOLING SYSTEM DESIGN**

Cooling and heat dissipation techniques are extremely important topics when it comes to designing and operating a data center. In many instances, system designs fall short of clients' expectations in terms of reliability and availability. Perhaps naively, often too much importance is placed on the power and network availability without the same being applied to the air conditioning systems. Remember, 'a chain is only as strong as its weakest link'. Infrastructure designs often fail to meet expectations because the same level of reliability/redundancy in many instances is not applied to all other components of the supporting infrastructure. While many people understand that only a short interruption in power supply to computer equipment can mean loss of data, what is often not considered is that an interruption in cooling system can be just as devastating.

This section summarizes several design factors that should be considered when planning the cooling of data centers. This section includes:

1. Heat gains
2. Temperature and humidity requirements
3. Ventilation rates
4. Air quality
5. Cooling loads
6. HVAC equipment

### **HEAT GAINS**

Each item of a data center hardware needs an adequate supply of cooling air to be supplied to it, and the heated air removed. The major heat gain in a data center is from the servers. For a server, every 1kW of power input typically dissipates 1kW of heating or, in other words, require 1kW of cooling. A typical data center can have hundreds of racks in the room, and each rack can have up to 42 servers. The heat gains per a square-foot of floor area will be significant.

Besides IT equipment, the other elements of heat gain are the solar loads from the building envelop (walls, roof and windows), ventilation air loads (building pressurization or people), auxiliary power supplies (lighting, electrical equipment such as UPS,

switchgear and cables, etc.). Cumulative, heat density can be as high as 300 watts/ft<sup>2</sup> of floor area. These heat gains need to be accounted for in the cooling load, and these are discussed further under cooling loads.

### **TEMPERATURE & RELATIVE HUMIDITY**

The American Society of Heating, Refrigerating, and Air Conditioning Engineers, ASHRAE Standard -2008 – “Environmental Guidelines for Data processing environments” recommends the following environment conditions:

- Dry bulb temperature: 64.4 to 80.6°F
- Dew Point\*: 41.9 to 59°F

The traditional way of specifying comfort conditions is by ambient room temperature and relative humidity (RH), but for data centers the optimum environment conditions are specified as cool supply air temperature to the servers and the dew point temperature (closely related to absolute humidity).

### **Effects of Temperature on Data Center Hardware:**

Equipment in the data center expends power, thereby generating heat and requiring air conditioning to keep them cool and running well. If the temperature rises too high, equipment will begin to malfunction or become damaged, as the internal components begin to swell and pull away from each other (or simply burn-up). Another important parameter that affects the failure rate of electronic circuits is the “temperature rate of rise” syndrome. Server and network equipment depend on high performance computer chips, which generate enough heat to damage themselves and nearby components. Any electronic device transitioning from cold temperatures to a warm temperature could form water condensation, thereby endangering the electrical shorts that trip circuit breakers and cause malfunction. Typically, the acceptable rate of rise figure is about 0.5°C/min. This parameter is directly related to the response time of the air-conditioning control system. Even though when the temperature is maintained within the acceptable range of 65 to 80°F, an acceptable rate of rise of 0.5°C/min is the time associated with plant re-start sequencing associated with the main refrigeration plant after a power interruption or power supply changeover.



### **Effects of Humidity on Data Center Hardware:**

Humidity must also be controlled to ensure continued functionality in the data center. If the air in the data center is too humid, water may condense on the internal components, resulting in shorts. If the air is too dry, a data center risks electrostatic discharge which can also result in electrical shorts. A static charge is when similar charges build up in a substance and do not immediately become neutralized with opposite charges. If the potential of a charged area becomes high, a powerful discharge occurs which may cause damage to the equipment by wiping out the memory, cause electrical shocks and create fire hazards. ESD is easily generated and less easily dissipated in areas when the relative humidity drops below 35%.

### **Relative Humidity or Absolute Humidity**

Traditionally for comfort applications, the room humidity is monitored in terms of relative humidity (RH) and is specified as  $55 \pm 5\%$ . But for data centers, the dew point or absolute humidity is considered the preferred and more realistic measure.

### **Why?**

Absolute humidity is a measure of the amount of water in the air independent of temperature while the RH expressed as a percentage measures the amount of water in the air at a given temperature. As air gets warmer, its volume increases and therefore relative humidity decreases, but the actual moisture or the absolute humidity stays the same.

The difficulty in the context of data centers is that these facilities deal with both warm air and cool air. The cool air flows into a server inlet and is heated and ejected as warm exhaust. The water content of this air didn't change during this process, but the relative humidity of the exhaust will be lower than that of the cool air at the inlet. The advantage of monitoring absolute humidity is that the inlet and outlet conditions at the server are same and thus a sensor can be placed just at the server inlet without the need to worry about getting a humidity measurement at the outlet as well. The absolute humidity of a data center, as measured in grams of water per grams of dry air, should be kept between 0.006 and 0.011.

A more familiar measure of absolute humidity is the dew point; the temperature at which water in the air begins condensing (or the temperature at which the RH is 100% for a given air mass). ASHRAE recommends the dew point temperature for data centers to be maintained at 41.9 to 59°F. It allows data center operators to standardize measurements from one side of the server to another and to better manage the natural variability in outdoor humidity levels.

### **VENTILATION AIR**

Ventilation (outside air supply) is required within the data center space for pressurization and to maintain acceptable indoor air conditions for the occupants. In this context the outdoor air requirements should be in accordance with ASHRAE Standard 62, which calls for a minimum 15 CFM per person. However, in almost all instances where the introduction of outdoor air is intended for pressurization purposes, it can be expected that the flow rates required will be in excess of that required for maintaining indoor air quality.

### **AIR FLOWRATES AND AIR QUALITY**

In order to dissipate high heat loads of data centers, the cooling systems must circulate enormous quantities of air. A heat load of 300 WPSF requires an airflow rate of 35 to 40 CFM per square-foot of the floor area. Scaling this up to a 10,000 square-foot data center would require an air-circulation rate of 350,000 to 400,000 CFM. This is lot of air and will require a number of fans and use considerable energy. Further, since the floor areas are limited; there may not be enough space for installing cooling equipment.

Air quality is equally important for electronic circuitry. Dust is certainly one of the worst enemies and can adversely affect the operation and reliability of data processing equipment due to stray currents. Generally, two factors should be considered in dust control: pressurization and filtration.

#### **Pressurization:**

The data center shall be positively pressurized to reduce air infiltration from the surrounding areas. The air tightness of data center rooms has to be sound, and the degree of over-pressurization has to be sufficient to neutralize the influence of wind forces, temperature differences and surrounding process spaces which may be

operating under negative pressure. A positive pressure level of 0.02 inches of water  $\pm$  .01 is recommended as the basis for design.

As a first step, the data center should be positioned indoor (not on the exterior), if possible, so that wind forces do not influence it. Second, the air tightness of the structure must be maintained for pressurization. This influences the design of the ventilation system, as well as the investment and operating costs.

All the designated openings such as doorways or the undesignated openings such as tiny air gaps around doorframes or other duct/piping penetration cracks will cause air leakage. This leakage is compensated by the HVAC system by distributing the controlled volumes of supply, return and exhaust airflow to the room. Consider the figure below, where Room 1 (data center) is connected to Room 2.

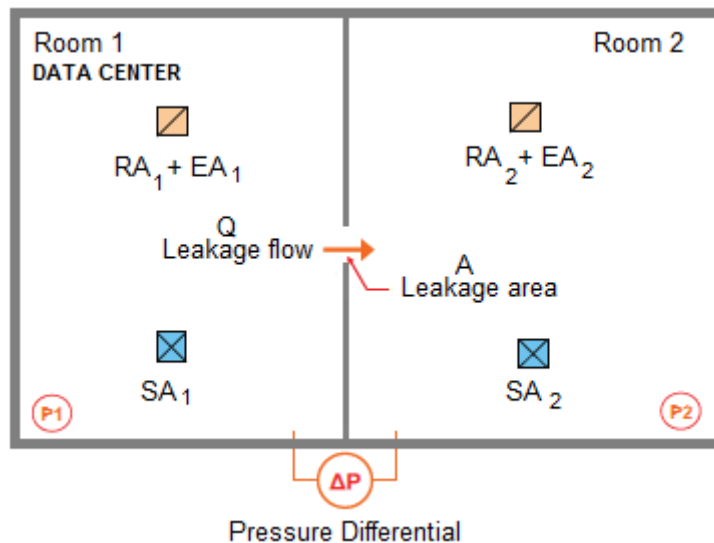

To achieve and maintain positive pressurization in Room 1,  $P_1 > P_2$ ; i.e. the supply air (SA<sub>1</sub>) must be greater than the return air (RA<sub>1</sub>) plus the exhaust air (EA<sub>1</sub>).

$$SA_1 > (RA_1 + EA_1), \text{ and}$$

$$SA_2 < (RA_2 + EA_2)$$

$$SA_1 = (RA_1 + EA_1) + Q$$

$$SA_2 + Q = (RA_2 + EA_2)$$

Q is the leakage (transfer) air from Room 1 to Room 2, if both rooms are tightly sealed, except for the opening between rooms.

### Airflow through the Opening

The specific relationship between room differential pressure, room leakage area and the differential airflow is expressed by the following equation:

$$Q = 2610 \cdot A \cdot (\Delta P)^{0.5}$$

Where

- Q = volumetric flow rate CFM
- $\Delta P$  = pressure drop across opening in. of water
- A = large designated opening areas, ft<sup>2</sup>
- 2610 = unit conversion factor dimensionless

The figure below also shows the relationship between differential pressure, room leakage area, and room differential airflow (the difference between the total room supply airflow and total room exhaust).

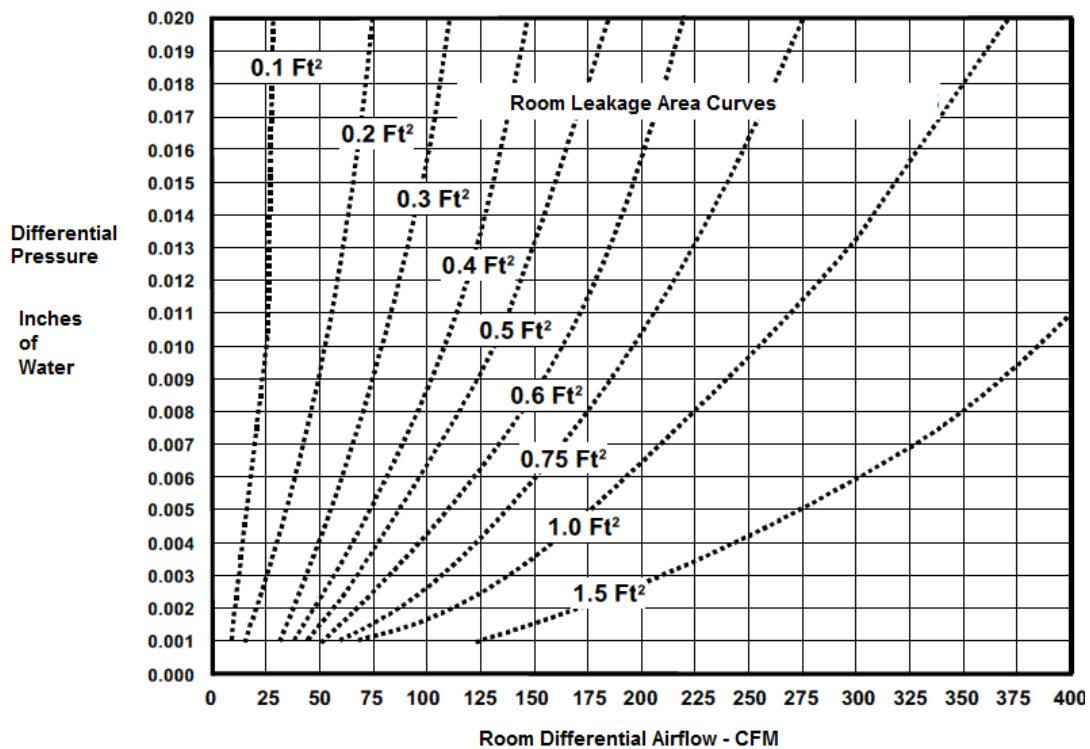

As seen from the figure, a room's differential pressurization value with respect to an adjacent area is totally dependent upon the room's differential airflow and the room's leakage area. For instance, the graph shows that to attain a differential pressure ( $\Delta P$ ) of 0.008 Inches of water for a room with a 0.75 square-foot leakage area, the difference between the room supply air and the total room exhaust needs to be 175 CFM. Therefore, to maintain a specific room differential pressure value, the room's differential airflow must be controlled and maintained at the proper value.

Note that neither room size nor its dimensions directly enter into the room pressurization relationship. The tighter the structure, the less outdoor air flow is needed to provide the desired room over-pressure. The operating costs will also be reduced. The worst leakage areas are service holes and crackage in the structure and it is essential that these be kept to a minimum.

**Filtration:**

All air entering the data center environment shall be filtered to at least MERV 10 in accordance with ASHRAE Standard 52.2 - 1999, Table E-1, corresponding to a dust spot efficiency of at least 50% with an arrestance exceeding 95%.

Special chemical or electrostatic air filtration may be necessary where installations are exposed to corrosive gases, salt air, or unusual dirt or dust conditions. It is important to ensure that this requirement is clearly identified beforehand; otherwise implementing such a requirement after the equipment is delivered to site could require fans to be upgraded to a higher static performance.

**COOLING REQUIREMENTS FOR DATA CENTERS**

**Units of Measurement**

A standard unit for measuring the heat is the British Thermal Unit (Btu). The heat produced or removed from data center equipment and auxiliaries is usually expressed as the number of Btu generated in an hour (Btu/h).

Watts (W) is also a term used to express heat. One watt is equal to 3.412 Btu/hr. For example, if you use 100 watts of power, you generate 341.2 Btu/hr.

Air conditioning capacity is also measured in Btu/h or watts. Large air conditioning systems are rated in tons. One ton of air conditioning is a unit of cooling equal to 12,000 Btu/h or 3.52 kW thermal energy.

**Cooling Loads**

Estimating cooling loads require an understanding of the amount of heat produced by the IT equipment and by other heat sources inside the data center. The total cooling requirement is the sum of the heat gains from:

- Heat released inside the space – IT equipment, UPS, power distribution, air conditioning units, lighting and people.
- Building envelope – heat from the roof, walls and windows; load varies with the outdoor environment.
- Ventilation air load – filtered outdoor air and infiltration; load varies with the outdoor environment.

The worksheet below makes it easier to determine the total heat output of a data center quickly and reliably.

Item	Data Required	Heat Output Calculation	Heat Output Subtotal
IT equipment (servers, switches, routers etc.)	Total IT load (sum of the power inputs of all IT equipment)	Same as total IT load power in watts i.e. 1kW of cooling per kW of power.	_____ watts
UPS with battery	Power system rated power (rating of UPS systems, excluding redundant modules)	$(0.04 \times \text{power system rating}) + (0.06 \times \text{total IT load power})$	_____ watts
Power distribution	Power system rated	$(0.02 \times \text{power})$	_____ watts

	power	system rating) + (0.02 x total IT load power)	
Lighting	Floor area in square feet or square meters, converted to watts.	2.0 x floor area (sq- ft)	_____ watts
People	Maximum number of personnel in data centers, converted to watts	100 x number of personnel	_____ watts
Ventilation air	Refer previous paragraphs for pressurization. A +ve pressure of 0.02±1 inches of water gauge is recommended.	Watts = .316 x Q x ΔT. Q = volumetric flow rate, CFM ΔT = temperature difference between the supply air and the fresh make up air.	_____ watts
<b>Total amount of cooling required</b>			_____ watts
<p>Note - Every watt equals 3.41 Btu of cooling load. HVAC designers can calculate the cooling load for each piece of equipment by multiplying the number of watts by 3.4 to produce Btu. The total Btu divided by 12,000 determines the tons of refrigeration.</p>			<p>Or</p> <p>_____ watt * 3.41Btu</p> <p>(Note: 1 watt = 3.416 Btu)</p>

**Example:**

A typical data center also has a cooling density (heat load) of 50 W to 150 W per sq. ft. A small data center sized for 5,000 sq. ft. is equal to [50W x 5,000 sq. ft. x 3.412 / 12,000 = 71 tons of cooling] at the low end and [150W x 5,000 sq. ft. x 3.412 / 12,000 = 213 tons of cooling] at the high end.

**Notes:**

1. **Equipment Heat Gains** – The data center equipment name plate describes the maximum amount of cooling required. But in almost all instances, equipment load cannot be easily calculated because the information regarding the equipment to be installed is quite simply not available. Experience plays a significant role in establishing the right load density and, wherever possible, valuable information can be obtained from conducting power audits of existing facilities. For guidance, the following guidelines may be adopted for estimating preliminary cooling loads:
  - Scarcely populated 20-40 watts per sq-ft.
  - moderately populated 50-60 watts per sq-ft
  - Densely populated 70-100 watts per sq-ft.
  - Heavily populated 100-150 watts per sq-ft.
  
2. **Building Envelope Heat Gains** – A data center room gains heat due to solar loads. If the data center is located in interior spaces having no exposed wall or windows, there will be negligible heat transfer through the building envelope. However, if walls or the roof get a lot of sunlight or there are other sources of environmental heat, the HVAC designer should assess how that affects the thermal requirement. Designers need to review the materials involved in the building's construction and select materials offering the greatest insulation against transmission of heat. Solar heat gains through windows should be eliminated by enclosing any existing windows with an insulated barrier. Additionally, any gaps that allow unnecessary infiltration/exfiltration need to be sealed and eliminated. From an energy conservation point of view, any heat



gains that are not directly due to IT server equipment represent an inefficiency that must be minimized.

3. **Occupancy** – Purpose built data centers normally don't have people working in them, but it is safe to assume occupancy of 2 or 3 persons. The heat output is around 100 watts per person. For ventilation purpose the outside air intake shall be based on building pressurization of 0.02 inches of water.
4. **Lighting** – Lighting loads are normally considered at 2 watts per sq-ft.
5. **Auxiliary Power** – The heat output of the UPS and power distribution systems consists of a fixed loss plus a loss proportional to the operating power. Conveniently, these losses are sufficiently consistent across equipment brands and models to be approximated without significant error.

### **COOLING EQUIPMENT**

Having calculated the cooling load, the next step is to decide the capacity and number of air conditioning units. The capacity of the cooling equipment is normally specified in BTU/h and is often expressed in tons of refrigeration, where one ton of refrigeration corresponds to a heat extraction rate of 12,000 BTU/h. The ton rating is very subjective because it is based on total cooling which is comprised of "sensible cooling" and "latent cooling."

- Sensible cooling is the ability to remove heat that causes a change in temperature, but no change in the moisture content.
- Latent cooling is the ability to remove moisture from the surrounding environment.

The cooling capacity stated for a comfort unit is usually its total cooling capacity (i.e. sensible + latent). But since the electronic equipment generates only the dry heat (no moisture), the sensible cooling capacity becomes the most useful value for data centers. The common way to express this is by the sensible heat ratio which is:

$$\text{Sensible Heat Ratio (SHR)} = \frac{\text{Sensible Cooling}}{\text{Total Cooling}}$$

For comfort air conditioning, the SHR is 0.60 to 0.70; that is the coil/air flow is designed to remove 30% to 40% latent heat load (moisture) and 60% to 70% sensible heat load. The cooling equipment for the data center is designed for 0.85 to 0.95 SHR; that is 85% to 95% sensible heat load and 5% to 15% latent load. These units will remove the high sensible heat load produced by the electronic equipment in a data center.

The cooling equipment used for data centers is commonly known as “Precision air conditioning units” or “Computer room air conditioners (CRAC’s)”. By design these virtually deliver 100% sensible cooling and maintain the temperature within closed tolerance of  $\pm 1^{\circ}\text{F}$  and  $\pm 3$  percent relative humidity of their design set point. Typical comfort systems simply cannot provide this level of control, and the very best that can be expected is  $\pm 3^{\circ}\text{F}$ . From an airflow standpoint, these provide a very large volume of air. If we compare this equipment to a comfort air conditioning system which moves air at a rate of about 400 cubic feet per minute (CFM) per cooling ton, the CRAC units are designed to move air at about 500 and 600 cubic feet per minute (CFM) per cooling ton. This is nearly twice the amount of air. The much larger air volume contributes to good air distribution and provides a better level of filtration.

We will learn more about the precision cooling equipment and system design options in the following section.

**SECTION - 3: DATA CENTER HVAC EQUIPMENT**

The types of cooling units available in the market can be broadly divided into comfort and precision computer room air conditioning (CRAC) units. The CRAC units are designed differently than comfort air conditioning systems. The biggest difference is that the comfort air conditioning systems are designed for human use, whereas the CRAC units are designed for the cooling of equipment. Since people are far more tolerant to the temperature and humidity swings compared to electronic equipment, the comfort air conditioning units don't have the strength or sensitivity for the job and simply cannot provide the kind of precise environment required by high-performance data center equipment.

The key characteristics that differentiate CRAC units from comfort air conditioning equipment are listed below:

	<b>Precision air conditioning (CRAC)</b>	<b>Comfort air conditioning</b>
Application	Designed to dissipate high heat loads.	Designed for human comfort perceived as pleasant by people.
Operating time	Server rooms operate 24 hours a day, seven days a week, 365 days a year. CRAC units are designed to operate continuously, non-stop.	Intermittent and cyclic operation only when people are working or occupying the area.
Redundancy	Offer redundancy and ensure minimal downtime.	Not designed or expected to operate non-stop, year round.
Proportion of capacity or sensible heat ratio (SHR)	Provide very high sensible heat ratio (SHR) - 0.85 to 0.95.	Typically has a SHR of 0.60 to 0.70, thereby providing little sensible cooling and too much latent cooling. This means that more capacity is needed to do

		the same job as a precision air conditioning system.
Controls	Equipped with microprocessor based controls, which are sensitive and respond quickly to environment conditions.	Generally have basic, limited controls. Unable to react or provide rapid control.
Control accuracy	Regulate temperatures and humidity within tight limits; $\pm 1^{\circ}\text{F}$ and humidity at $\pm 3\%$ .	Can't regulate humidity and temperature within precise margins.
Technology	Provide up to six stages of cooling, using inverter compressors across multiple refrigeration circuits. Inverter compressors ramp up quickly, providing the energy necessary to achieve the cooling or heating demand of the zone. Then, working in tandem with system controls and sensors, the inverter compressor varies its speed to maintain the desired cooling level.	Smaller units (less than 5 tons) provide generally single stage cooling. Typically use fixed speed reciprocating and scroll compressors that operate at 0% and 100%, wasting energy when partial load conditions prevail. And even with 2 or 3 stages, it doesn't compare to the full-range variable capacity of the inverter-driven system that fully supports part-load operation.
Heat exchangers	Evaporators designed for high $\Delta T$ across the coil. ( $\Delta T$ is the temperature difference between the return air and supply air temperature which by design is 16-20° across the evaporator coil).	Evaporators designed for 10 to 12° $\Delta T$ across the coil. This is necessary to achieve optimum moisture removal.

<p>Humidity regulation</p>	<p>Have the ability to control the humidity levels to the space. The units can add humidity with a humidifier that is built into the unit.</p> <p>Excessive moisture in space is controlled by activating the cooling coil in cooling mode and activating blower to lower speed (variable frequency drive), to increase the air contact time to the cooling coil. The temperature difference between the air over the coil and the cooler coil temperature will wring out the moisture from the air.</p>	<p>Achieve unregulated dehumidification suitable for comfort cooling.</p>
<p>Air volume</p>	<p>Operate at a high air flow rate from 500 to 600 CFM per ton or greater. The high volumetric rates are necessary to remove hot spots allowing more air through filters ensuring a cleaner environment.</p>	<p>Typically operate at a much lower airflow ranging from 350 to 400 CFM per ton of refrigeration.</p>
<p>Air quality</p>	<p>These units clean air continuously through the high-efficiency air filters and the system design of the blower operating all of the time.</p> <p>There are different levels of efficiency for air filters, which are indicated by the MERV numbers. In general the higher the MERV number, the higher the efficiency.</p>	<p>Use disposable or washable filters of undetermined efficiency. Not intended for clean applications.</p>

Diversity of options	Very large due to individual production.	Lower, due to mass production.
Operator controls	Technical and complicated	Intuitive and simple
Energy efficiency	<p>Some of the inherent efficiency features include:</p> <ul style="list-style-type: none"> <li>– Use of inverter driven compressors, which are low on energy consumption and provide excellent part load efficiency.</li> <li>– Use of variable speed fan along with multistage cooling. This improves the dehumidification process.</li> <li>– Use of hot gas reheat capability during the de-humidification process by utilizing heat energy that would normally be rejected outside by the condenser.</li> </ul>	Designed with standard components.

**OPTIONS FOR HARDWARE COOLING**

Two approaches can be adopted to cool the servers: 1) Air cooling, and 2) Liquid cooling (typically water, glycol or some form of refrigerant).

1. **Air Cooling** – Air cooling refers to dissipating heat via cool air. It offers some obvious benefits: it doesn't hurt IT equipment; it easily passes through server racks; and it's relatively easy to circulate. However, generation of temperature gradients (hot spots/cold spots) in the space will tend to happen if the cooling system is designed improperly or IT equipment/servers are arranged in clusters.

2. **Direct Liquid Cooling** - Direct liquid cooling refers to targeted cooling near the point the heat is generated, rather than transferring it to room air and then conditioning the room air. Water for instance has a very large specific heat and density relative to air, thus requiring much less volume than air per unit of heat being transferred. By locating a cooling coil adjacent to hot equipment, the water can directly convect away the heat load. One caveat about water heat exchange, however, is that it requires careful construction so as not to damage the IT systems in case of failure or leakage.

Most data centers use air as a cooling medium and in this course we will focus on air as the cooling media.

### **Different Cooling Equipment**

The two types of equipment used for cooling are: 1) Direct Expansion (DX) systems, and 2) Chilled water systems.

1. **Direct Expansion (DX) Systems** – A DX system is self-contained air conditioning unit that uses refrigerant directly to cool air. A DX system pumps refrigerant through the evaporator coil through which air is blown. The air gets cooled and the heat is transferred to the refrigerant and is released to the ambient atmosphere. According to the type of condenser used, the DX system has air-cooled and water-cooled heat rejection options. The units are generally less expensive compared to the central chilled water systems.
2. **Chiller based cooling:** A chilled water system utilizes a secondary cooling medium, i.e. the refrigeration cycle first produces chilled water, which in turn is used to cool air. Water lends itself as a superior cooling medium primarily on the account of its easy controllability and it doesn't have any distance limitations.

Both DX and chillers utilizing mechanical vapor compression refrigerant cycles use synthetic refrigerants. The three most common refrigerants in use today are R407C, R410A and R134A; all belong to the group of alkyl halides. All are zero ozone depleting but exhibit global warming potential. The environmental impact of R134A with respect to greenhouse gas emissions is slightly less than that of either R407C or R410A. R410A global warming potential is slightly lower than that of R407C.

### Choice of Air Distribution Pattern

The cooling units are available with both the top discharge (up-flow) and the bottom discharge (down-flow) configuration.

- In the up-flow units, the supply air is discharged from the top either directly into the computer room or into the ceiling space from which it will enter the room from ceiling diffusers.
- In the down-flow units, the air intake is from the top and the discharge is through the base. This configuration is more commonly used in data centers that are designed on the concept of raised floor.

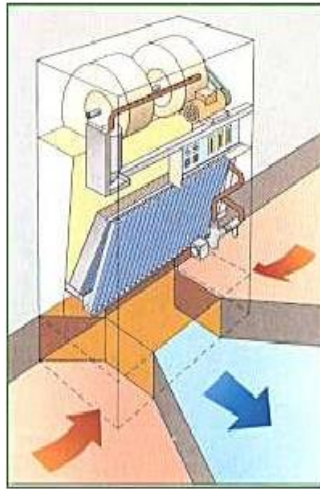

### Down-flow type Air Handling Unit

Supply air is discharged into the space under the raised floor from which it will enter the room through perforated grilles or diffusers. The air is directed into the front of the IT racks, and the heat is exhausted from the rear of the racks. The hot air is drawn to the ceiling and recycled back to the cooling unit.

### DX AIR-CONDITIONING UNITS

DX air conditioning is the most common type of cooling for small and medium sized data centers. These are available as fully contained packaged units with the condenser and cooling units in one enclosure or split configurations. In a split-system there are two parts: an outdoor metal cabinet and an indoor cabinet. The outdoor cabinet contains the



condenser and compressor and typically sits outdoors. The split configuration is more common and is available with the following three options:

1. DX Split A/C System - Air Cooled
2. DX Split A/C System - Water Cooled
3. DX Split A/C System - Glycol Cooled

### DX Split A/C System - Air Cooled

The DX split a/c – air cooled system refers to a system where the cooling unit (CRAC) is placed in or near the conditioned area and the air cooled condenser for heat rejection is located elsewhere outside of the building. An air-cooled condenser is cooled by the environment air. The refrigerant circulates between the indoor and outdoor components in pipes called refrigerant lines. Heat from the indoor environment is “pumped” to the outdoor environment using the circulating flow of refrigerant.

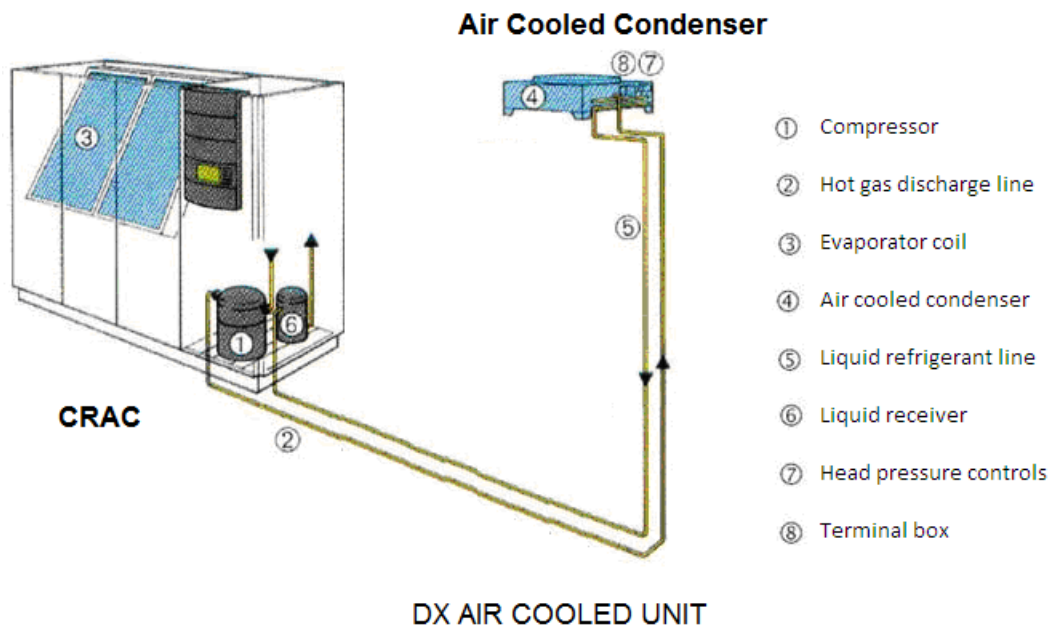

The compressor resides in the CRAC unit but configurations are available where it is installed outdoors along with the condenser. When the compressor resides in the condenser the general terminology for the air cooled condenser is “condensing unit”, and the overall system is known as a split system.

### **Advantages**

- Each system is a self-contained, stand-alone module, smaller footprint and easier installation in spaces;
- Usually multiple units are installed; if one unit breaks down, the other units can take over the cooling load, ensuring reliable, fail-safe operation;
- Additional units can be added any time to take care of the increased loads and future expansion;
- The a/c units may be located close to heat sources, thereby resulting in higher cooling efficiencies; and
- Generally they are cheaper to install and redundancy can be achieved by adding extra units.

### **Disadvantages**

- Refrigerant piping (two per compressor) must be installed in the field. Only properly engineered piping systems that carefully consider the distance and change in height between the IT and outdoor environments will deliver reliable performance. The design must address pressure losses, refrigerant velocities, oil return, and traps; and
- Multiple computer room air conditioners cannot be attached to a single air-cooled condenser.

### **Applications**

The air-cooled chillers are preferred for small or medium installations (3 to 50 TR) capacity. An air-cooled chiller is preferred especially when there is not enough water or when the water is very expensive.

### **Caution:**

The split arrangement is achievable when the interconnecting refrigerant piping is not very large (typically less than 50 ft.). Apply the manufacturer's recommendations.

### DX Split A/C System - Water Cooled

DX split a/c – water cooled systems are similar to air cooled units in a way that all refrigeration cycle components are located inside the CRAC. The difference is that the heat rejection is through a different medium.

A water-cooled CRAC includes a remote cooling tower and a cooling water supply. A compressor is typically located in a floor-mounted unit with a shell and tube heat exchanger (water cooled condenser), an evaporator fan and cooling coil. A water cooled condenser is connected via a non-insulated condenser water piping circuit to a central cooling tower. A pump package (pump, motor, and protective enclosure) is used to circulate the cooling water in its loop to and from the condenser to the cooling tower. Water pipe design is a lot less critical and easier to install than refrigerant piping.

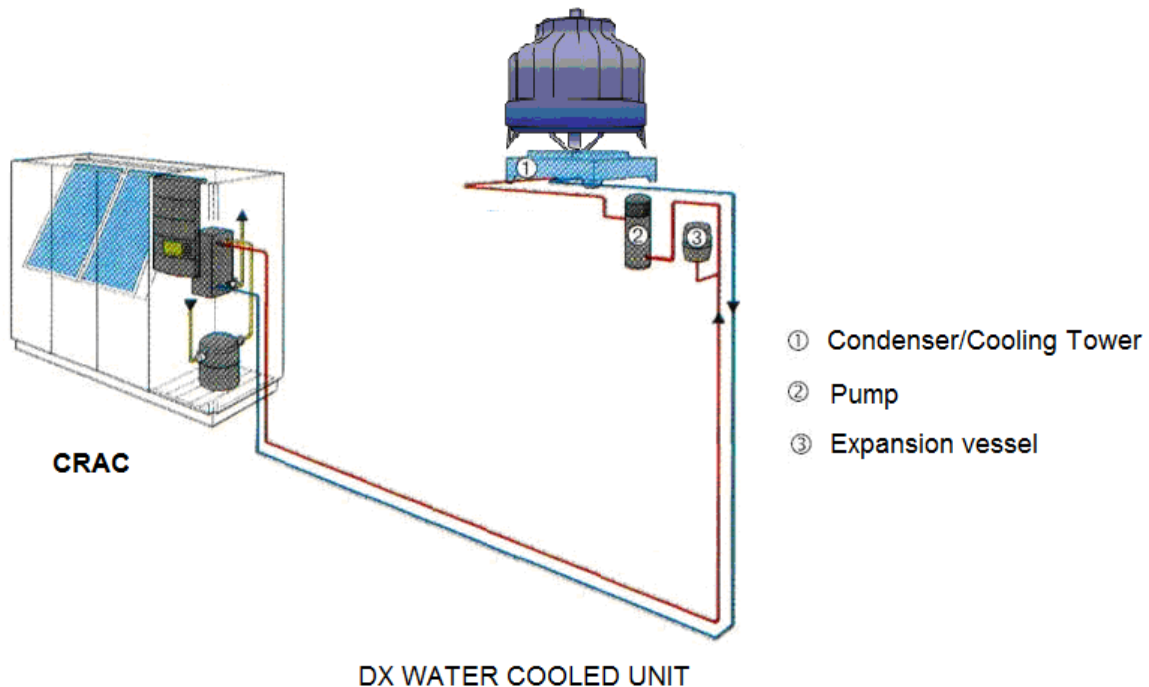

### Advantages

- All refrigeration cycle components are contained inside the computer room air conditioning unit (CRAC) as a factory-sealed and tested system for highest reliability;

- Condenser water piping loops are easily run long distances and almost always service many computer room air conditioning units and other devices from one cooling tower;
- In leased IT environments, usage of the building's condenser water is generally less expensive than chilled water; and
- Water cooled systems may be preferred because of better heat transfer properties of water as compared to air cooled systems. The primary advantage of water is that the film coefficient is 10 to 100 times better with water than air. The film coefficient controls heat transfer with a given constant area and temperature difference.

#### **Disadvantages**

- High initial cost for the cooling tower, pump, and piping systems;
- Very high maintenance costs due to frequent cleaning and water treatment requirements;
- Introduces an additional source of liquid into the IT environment;
- Cooling tower should be winterized in cold and temperate climates; and
- Water treatment is almost necessary when a cooling tower is used.

#### **Applications**

The water-cooled systems are usually preferred for medium and large installations (10 TR and larger) and where there is sufficiency of water. In addition, they are also preferred in cases that demand constant performance of the system, independently of the ambient temperature, because the capacity of the water-cooled systems is not much affected by the ambient temperature fluctuations.

#### **DX Split A/C System – Evaporative Condenser**

Evaporative condensing units are very similar to water-cooled systems except that the heat rejection occurs in an outdoor liquid-to-air heat exchanger commonly called a "dry cooler." A glycol solution (a mixture of water and ethylene glycol, similar to automobile anti-freeze) is generally substituted for water if outdoor temperatures are expected to go

down below the freezing point during the winter. A pump package (pump, motor and protective enclosure) is used to circulate the glycol in its loop to and from the condensing unit and the dry cooler.

Dry coolers are lower maintenance than cooling towers. What makes the evaporative condenser efficient is an elimination of one heat-exchange process. The hot gas from the compressor is condensed in a coil located in an adjacent cooling-tower-like enclosure, where recirculated water flows directly over the hot gas coils while a fan pulls ambient air through the enclosure, evaporating and cooling the recirculating water. In this manner, heat exchange losses in the shell-and-tube condenser of the CRAC are eliminated.

The dry-cooler eliminates the need for a cooling tower with all its usual problems of scale formation and large quantity of makeup water required. However with two heat exchangers in the water circuit, the head pressure will be at a higher level than with a normal condenser/cooling tower combination.

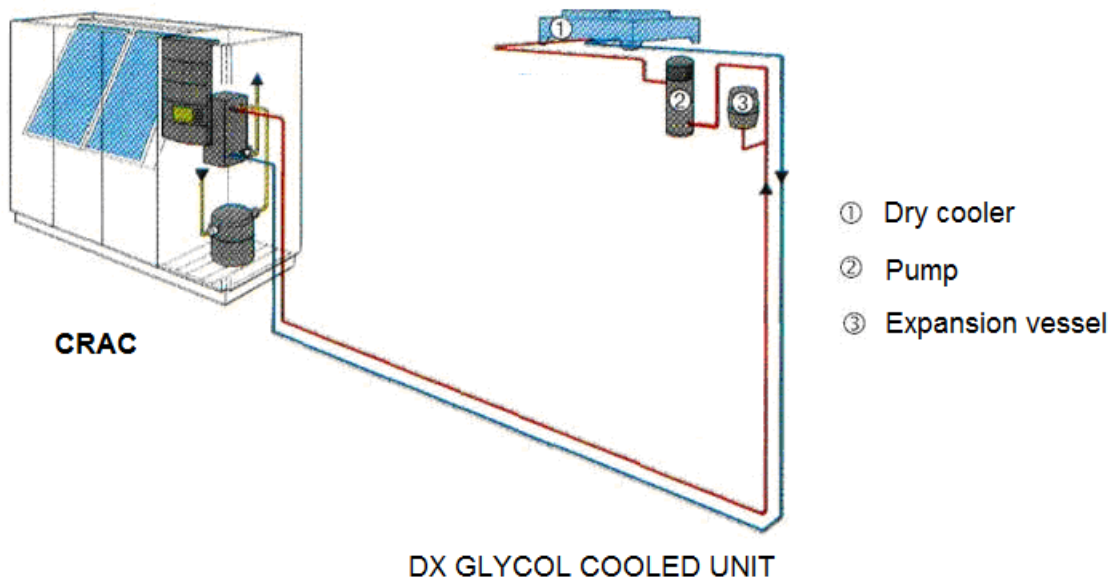

**Advantages**

- Offer same advantages as water cooled units, with the additional advantage that it presents excellent opportunity for heat recovery. In cold locations, the glycol

within the dry cooler can be cooled so much (below 50°F) that it can bypass the heat exchanger in the CRAC unit and flow directly to a specially installed economizer coil. Under these conditions, the refrigeration cycle is turned off and the air that flows through the economizer coil, now filled with cold flowing glycol, cools the IT environment. This economizer mode, also known as “free cooling”, provides excellent operating cost reductions when used; and

- Water treatment is not required as in a water cooled system.

### **Disadvantages**

- Additional required components (pump package, valves) raise capital and installation costs when compared with air-cooled DX systems; and
- Maintenance of glycol volume and the quality within the system are required.

### **CENTRAL CHILLED WATER SYSTEM**

In large data centers, where cooling loads are in the order of thousands of tons of refrigeration, a centralized chilled water plant will be more efficient. In this type of system:

- Chilled water is supplied from a central chiller plant to the cooling coils in computer room air handlers (CRAH's) placed in or near the conditioned area.
- The refrigeration system is contained in the remote chiller plant located outdoors in open or in a mechanical room.
- Indoor CRAH's contain controls, chilled-water coil, chilled-water control valve, blowers, filters, humidifiers and reheat.
- Chilled-water temperature is maintained as high as possible to keep a high sensible heat ratio (47°F / 8.33°C or higher).

There are three main types of chiller arrangements distinguished by their heat rejection configuration. Chilled water supply and return is similar in each configuration.

### Water cooled chillers

With water cooled chillers, the refrigerant is cooled with a shell and tube condenser that is part of the chiller package. The condenser water heat is then rejected to the cooling tower located outdoors.

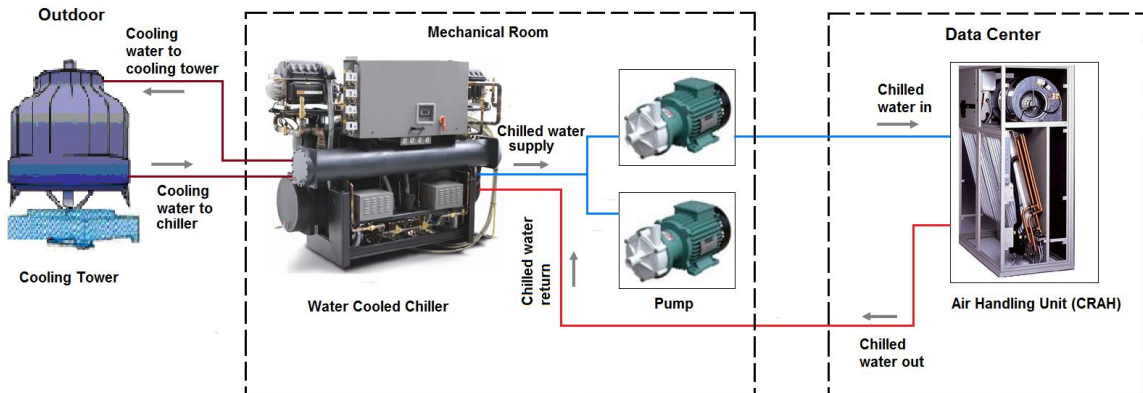

### Glycol cooled chillers

Glycol-cooled chillers look identical to the water-cooled chillers. With glycol-cooled chillers, heat removed from the returning chilled water is rejected to a glycol loop for transport to the outside atmosphere. The glycol flows via pipes to an outdoor-mounted device called a dry cooler also known as a fluid cooler. Heat is rejected to the outside atmosphere as fans force outdoor air through the warm glycol-filled coil in the dry cooler.

### Air cooled chillers

With air-cooled chillers, the heat of refrigerant is rejected to an air-cooled condenser that is typically integrated with the chiller. This type of chiller is known as a packaged chiller and can also be integrated into a cooling facility module. Air-cooled chillers are typically located outdoors.

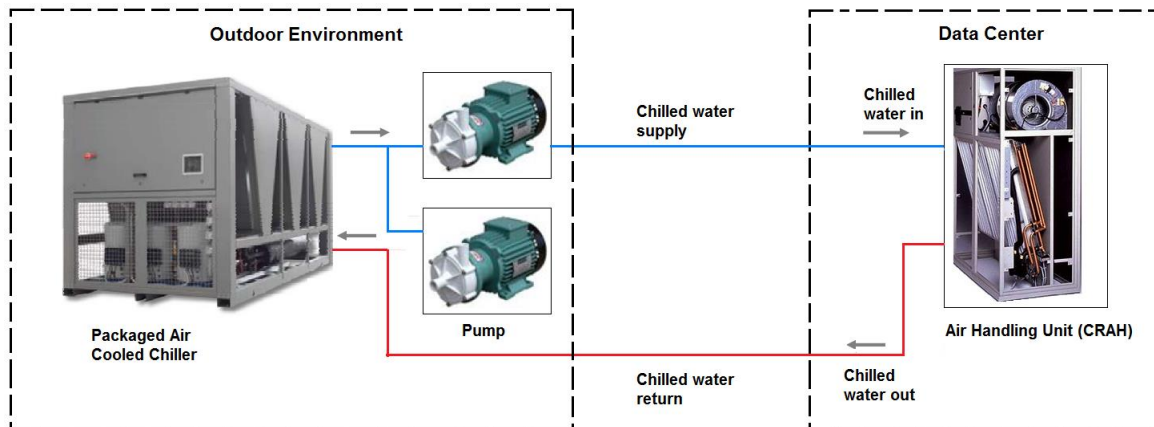

**Caution:**

Since cooling loads for data centers are primarily sensible heat, the chilled fluid temperature should be maintained as high as possible. The chilled-water supply temperature for data center cooling is around 47°F as compared to 42°F for comfort applications. This indicates that for a similar heat load, the chilled water flow rate shall be approximately 20% higher than the comfort air conditioning system to achieve the same degree of performance. The chilled water piping should be sized accordingly. Combining the data center room chiller with the comfort cooling applications is NOT recommended.

Redundancy should be extended to central chilled plant and pump packages. Redundancy in CRAH may not be required if there are multiple units installed; however, it is good practice to keep a standby fan motor in stock.

**Applications**

Usually 80 TR and larger are used in data centers, with moderate-to-high availability requirements.

**Disadvantages**

- Chilled water systems generally have the highest capital costs for installations below 100 kW of electrical loads; and
- Introduces an additional source of liquid into the IT environment.



**Comparison - DX v/s Chiller System**

For small data centers, the DX system offers significant advantages over chiller water design. The comparisons below highlight some of the advantages offered by a DX system over the chiller system.

Parameter	DX-Central	Chiller
Space	Eliminates space requirement for large central compressor plant room & increases leasable floor area.	Large mechanical plant room required.
Capital Cost	Lower cost. The initial capital investment is typically 20% lower for a DX central installation.	Higher capital cost investment upfront in the procurement and installation of chiller, cooling tower, pumps etc.
Energy Cost	Although energy consumption (kW/ton of refrigeration) is high compared to chiller system, the multiple small DX units operate only on demand of the individual user in each area.	Chiller operates with higher COP and has lower power consumption (kW/ton). But the chiller system operates regardless of load demand, i.e. 10% cooling demand will generate cooling call for entire plant.
AMC cost	DX units are inexpensive to maintain, reliable operational track record and faults are quickly rectified.	Central plant chiller AMC costs are high due to labor intensive maintenance regimes and expensive capital components.
Skilled Labor Requirements	Does not require specialized, trained technicians.	Specialized, trained central plant chilled water technicians required for maintenance and repair.
Spare Parts	Small, economical and easily available, complete range of parts can be stored at site for low cost.	Chiller parts are expensive, available only from the manufacturer and not ex-stock in most cases.
Compressor Failure	In the event of compressor failure, the single machine only is affected	Chiller compressor or motor failure results in extended downtime of

	<p>and the compressor is easily and quickly replaceable.</p> <p>The entire machine can also be replaced in just 2-3 hours at low cost.</p>	<p>several weeks and very high cost.</p>
Complete Failure	<p>Complete failure of machine only affects the local service area.</p>	<p>Complete failure of chiller can affect the whole facility.</p>
Power management	<p>Multi-metering can be installed per unit allowing individual tenancies to be responsible for energy consumption outgoings.</p>	<p>Chiller system is common for all tenants causing difficulty with running cost segregation between tenancies.</p>
Flexibility	<p>Adding or deleting to an existing DX central system for Building modifications or extensions is easily undertaken at low cost.</p>	<p>Chilled water central plant equipment is fixed at initial design stage and cannot be easily altered.</p>
Future Expansion/Up gradation	<p>Staged developments can benefit by way of proportional cost for unit and equipment purchase in line with future expansion.</p>	<p>Staged developments must make full upfront investment for all HVAC major components. No added value available for facility expansion.</p>
Installation	<p>Installation process is efficient and easily managed in building construction schedule without technical complications and delays.</p>	<p>Chiller system installation requires high degree of technical input and may require lot of building interface and supervision. Possible construction delays.</p>
Commissioning	<p>Commissioning does not require specialist skills and can be undertaken quickly and cost effectively.</p>	<p>Commissioning is more elaborate with critical processes.</p>
Piping	<p>Condenser water pipework design and installation is a simple</p>	<p>All chilled water pipe from plant room to each machine requires insulation.</p>

	process. No insulation is required for piping therefore no condensation risk in ceiling and roof slabs etc. No thermal loss or long term deterioration risk. Also no harmful carcinogenic insulation material in occupied space.	Condensation and efficiency problems, resulting in thermal loss, can develop after installation or over a period of time after insulation deterioration. Chilled water system design and installation is critical for effective transportation of cooling water throughout building. Minor errors can create performance issues.
Essential services power Back UP	A backup power system for equipment servicing essential areas is easily and cost effectively provided with minimum DG set for emergency operation.	Any DG back up system requirements need to account for the entire power load of the HVAC plant.
Electrical installation and mains cabling	DX units start and stop at different times reducing the electrical maximum demand calculation for the facility. Also smaller transformers and capacitor banks due to no requirement for voltage drop allowance on high Chiller Compressor start up current draw.	High starting current demand requiring allowance in building electrical system design.
Electrical Fluctuations	DX-Central system is robust and cooperative with fluctuating and unreliable electrical power supply.	More prone to failure and damage with such occurrences specifically after the initial warranty period. Chiller unit micro-processor control systems are very susceptible to erratic power supply conditions.
Controls/BMS/Operators	DX-Central systems do not require expensive BMS or site operators for optimum system performance.	BMS systems are generally required to operate chiller water systems. This provides operating cost additions.

### System Design for Redundancy

A common practice for applying redundancy is to adopt n+1 philosophy for all major equipment, so that a single equipment failure can be tolerated without affecting system performance. As an example, if the heat load works out to 45 tons, one can select three units of 15 tons each as operational plus one unit to work as a standby (commonly referred to as  $n = 3 + 1$ ) or select two units of 22.5 tons each as operational plus one unit as a standby (referred to as  $n = 2 + 1$ ). The total price of each selection and the physical constraints at the installation site will finally determine the best choice.

However, n+1 level of redundancy is simply not resilient enough to approach the 99.9999% (“Six Sigma”) system availability. In order to achieve this 99.9999% system availability, the allowable annual downtime is limited to less than 32 seconds a year. To achieve these levels of system availability, system designs are becoming increasingly complicated and expensive. A system designed around n+1 philosophy for redundancy can have multiple points where a single failure could result in the system becoming inoperable; e.g. power supply arrangement, common pipe work headers, etc. To illustrate this, take for example a data center equipped with air-cooled packaged units having n+1 redundancy and refrigerant pipes together with control and power supply wiring routed via a riser shaft to independent condensing units on the rooftop (refer to the figure below).

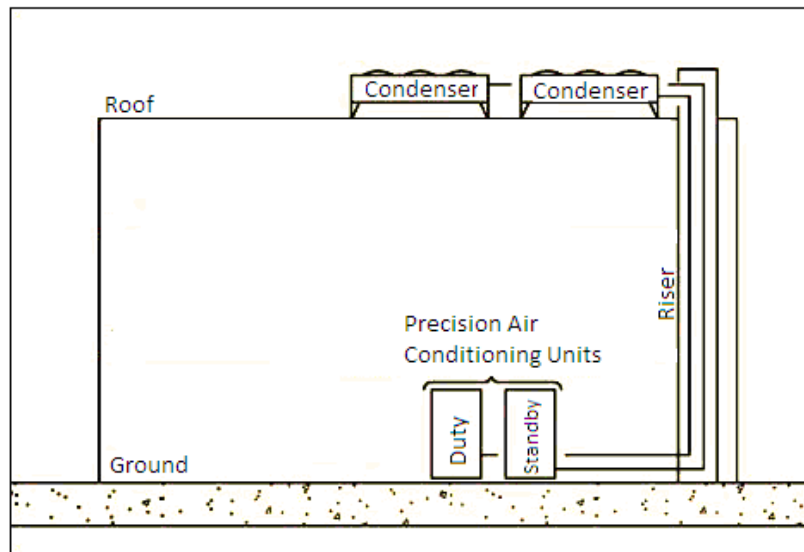

Typical Air Cooled System Installation

While this configuration does appear to provide a fully n+1 redundant system, it is not the case. The fact that the refrigerant pipes together with control and power supply wiring are routed in a common riser shaft can be considered as a physical (rather than technical) single point of failure, the same is true for the location of the condensing units on the rooftop. The common riser shaft and common location for condensing units could increase the chances of total system failure if say; the walls of the riser shaft were not fire rated and a fire which if started within one of the floors spreads to the riser damaging control cabling or in the case of the condensing units on the rooftop if a saboteur gained access. Whilst these examples may be considered unlikely, the fact is that they do exist and in albeit rare instances, could threaten the operation of the data center. An alternative configuration which could be considered more resilient is to locate the redundant condenser at the ground floor in some form of lockable compound (refer figure below).

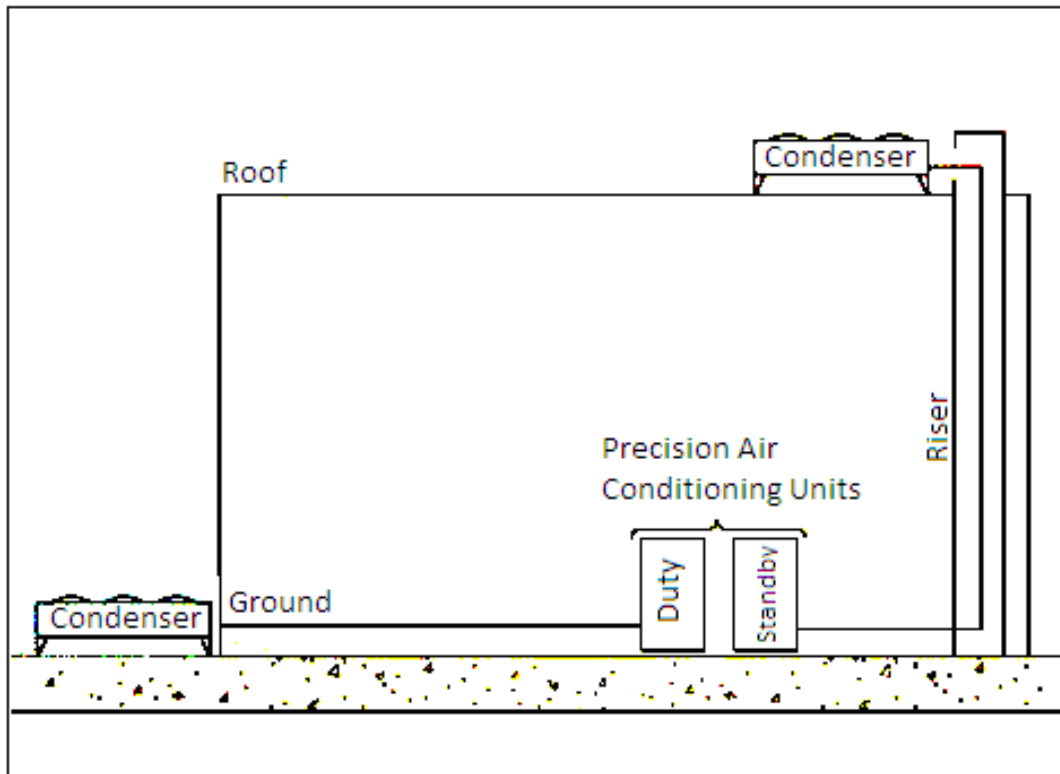

Alternative Air Cooled System Installation

## Electrical Redundancy

When considering the use of a centralized chilled water plant in the design of any computer room air conditioning system, engineers must also carefully consider plant restart time and its effect on the rate of rise of temperature. For example, consider a simple chilled water system incorporating two chillers: one duty and one standby, which are provided with a utility power supply and alternative emergency diesel generator supply via auto-changeover (see the figure below).

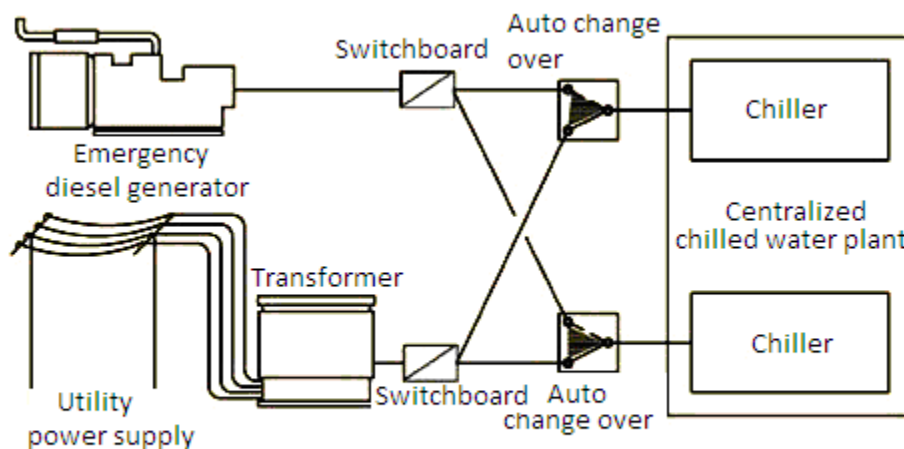

**Chilled Water Plant with Redundant Power Supplies**

In the event of an interruption to the utility power supply, the system would automatically changeover to the emergency diesel generator supply. However, the interruption in the supply while the generator starts means there is a momentary power loss to the chillers. While uninterrupted power supply systems make this transparent to the ICT equipment, in most cases it is not considered practical to provide such systems for a chilled water plant. This momentary interruption triggers the chillers' various safety devices and control checking sequences, which can result in a time delay of more than 10 minutes before the systems return to full capacity. While this would be of no consequence in most comfort air conditioning applications, in data centers where loads may be in excess of 150 watts/sq.ft., the rate of rise can very quickly result in critical indoor conditions. To overcome such problems, engineering solutions should consider fluid buffer tanks or some other means of thermal storage to reduce the temperature rise during this period.

## **Recommendations**

1. Capacities: < 80 tons use CRAC, DX System
  - Total Energy = 1.4 kW/ton
2. Capacities: > 80 tons and < 200 tons use chilled water systems, screw chillers:
  - Water cooled/water screw chillers: 0.68 kW/ton;
  - Condenser water pump: 0.026 kW/ton;
  - Chilled water pump: 0.021 kW/ton;
  - Cooling tower: 0.012 kW/ton; and
  - Air handling unit: 0.086 kW/ton.

Total = 0.83 kW/ton.

3. Capacities: >200 tons use chilled water systems, centrifugal chillers:
  - Centrifugal chiller: 0.48 kW per ton, variable speed drive;
  - Condenser water pump: 0.021 kW per ton (3 gpm/ton, 30' TDH, 0.85 eff. pump, 0.92 eff. motor);
  - Chilled water pump: 0.021 kW per ton (2.4gpm/ton, 60' TDH, 0.85 eff. pump, 0.92 eff. motor);
  - Cooling tower: 0.011 kW per ton; and
  - Air handling unit: 0.098 kW per ton (400 cfm/ton, 1.5" TSP, 0.80 eff. fan, 0.90 eff. motor).

Total = 0.68 kW per ton.

## **Cooling cost savings from more efficient conventional cooling systems**

For a normal 10,000-sq.ft. facility, including all cooling equipment (not just the chiller) operated at 8,766 h/y and paying \$0.09/kW/h, with a 300-ton cooling load (1 ton = 3.52 kW thermal = 12,000 btu/h), the table below provides the following data:

<b>Technology</b>	<b>\$/ton</b>	<b>First cost (\$)</b>	<b>Investment premium (\$)</b>	<b>kW/ton (COP)</b>	<b>Annual operating costs (\$)</b>	<b>Annual costs savings (\$)</b>	<b>ROI%</b>
CRAC (DX)	1600	480000	0	1.4 (2.5)	331000	0	0
Water/Evaporative cooled CRAC	1680	504000	24000	0.9 (3.9)	213000	118000	492%
Rotary Screw Chiller	2400	720000	240000	0.83 (4.2)	196000	135000	56%
Centrifugal Chiller	2800	840000	360000	0.68 (5.2)	161000	170000	47%

Source: Design Recommendations for High-Performance Data Centers, Rocky Mountain Institute (RMI), Snowmass, CO, USA



**SECTION - 4: DATA CENTER AIR DISTRIBUTION**

Supply air distribution is probably the most important aspect of data center cooling. Two design configurations are common: 1) raised floor system, and 2) overhead air distribution.

**Raised Floor System**

A raised floor is a data center construction model in which a slightly higher floor is constructed above the building's original concrete slab floor, leaving the open space created between the two for wiring and supplying cold air. The static pressure in the supply plenum pushes the air up through perforated floor tiles and the warm exhaust air rises to the ceiling and flows along the ceiling back to the top of the HVAC unit to repeat the cycle. The advantage of a raised floor installation is that the cold air is directed primarily to the equipment racks and the entire room space is not cooled uniformly. The figure below illustrates the raised floor air distribution system.

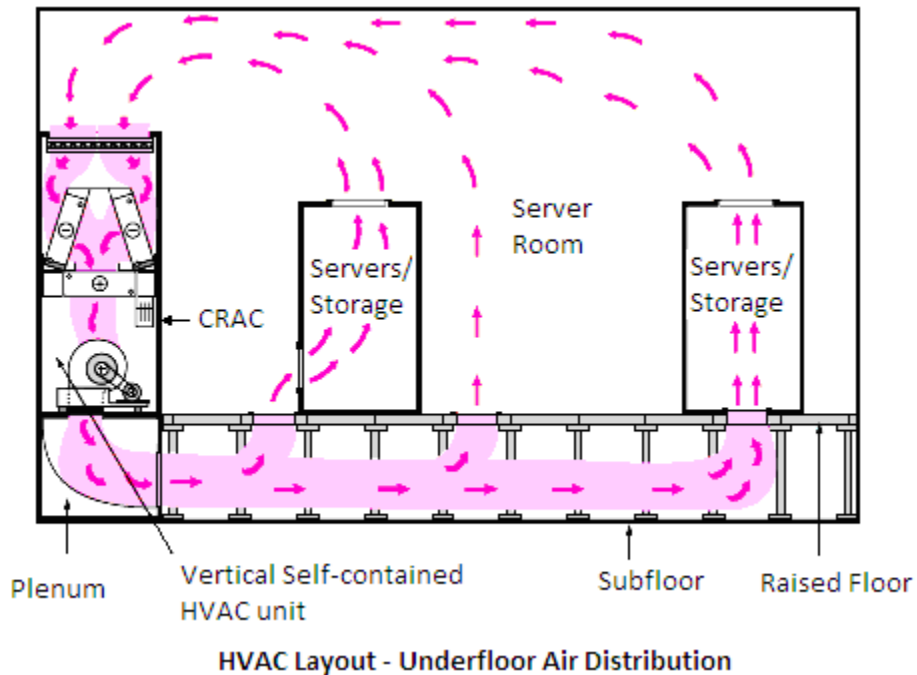

**Overhead Air Distribution**

Overhead air distribution (OH) systems supply conditioned air through ducts at the ceiling and typically take return air at the lower level or through a plenum above the

ceiling. The diffusers connected to the supply duct system are designed to throw air around the room in such a manner that the entire data center space is filled with air and the whole space temperature is maintained fairly even (the same way you might want to cool a room in your house). This approach leads to heavy mixing of the hot and cold air flows and is not an energy efficient method.

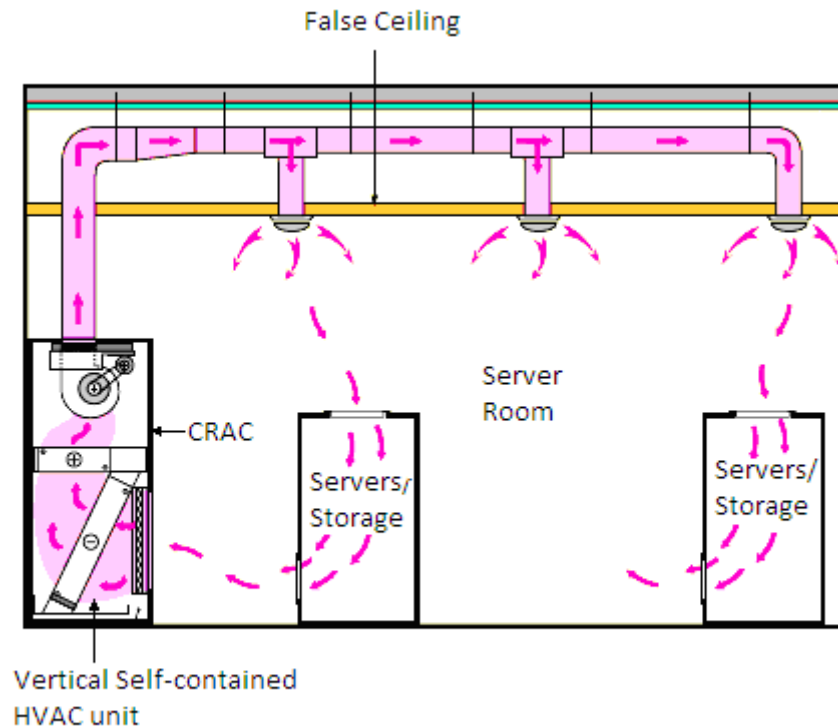

HVAC Layout - Overhead Air Distribution

### Comparison Raised Floor v/s Overhead Cooling

Raised floor air distribution offers significant advantages over overhead cooling and is, by far, the most popular choice in data centers. The comparisons below highlight some of the pros and cons with raised floor systems:

#### Raised Floor Advantages

1. As the conditioned air is supplied through the bottom, the electronic equipment cools much faster and efficiently;

2. Raised floor cooling provides high induction rates and consequently the supply may be located close to the computer equipment without the danger of unmixed supply air entering the equipment;
3. A higher supply air temperature is possible since the cool air is targeted close to the equipment. Since the entire room need not be controlled, the air handling and refrigeration tonnage capacity can be reduced;
4. A higher return air temperature can be tolerated without affecting the design conditions of the overall room;
5. The raised floor plenum acts as pathway for the supply air, hence the ducting is eliminated or reduced;
6. The equipment layout can be changed at any time and conveniently by relocating the supply floor diffusers. The floor tiles can also be removed and replaced conveniently to allow for maintenance; and
7. Raised floor air distribution requires only  $\frac{1}{4}$  to  $\frac{1}{2}$  inch water gauge (in-wg) static pressure against  $1\frac{1}{2}$  to 2 in-wg in an overhead ducted system. Low static pressure implies lower fan power consumption and lower noise levels.

### **Challenges**

1. The raised floor system, if not correctly installed, is a major contributor to air leakages, uneven air distribution, and hot spots;
2. An important precaution for raised floor plenum design is the need for insulating the true floor to avoid condensation, especially when the supply air temperature in the plenum drops below the dew point. The other concern is the possibility of flooding. Moisture/water sensors must be placed under the flooring to detect this;
3. Cable trays that run under the floor may cause obstructions and blockages to air flow. In many instances, perforated tiles deliver substantially less airflow than expected due to blockages and obstructions under the raised floor;
4. Fire suppression systems should also be deployed under the raised floor, as the smoke from a fire could go undetected by ceiling mounted smoke detectors;

5. A raised floor frame must be designed to accommodate the anticipated load of data center equipment. Cabinets full of equipment can weigh as much as 3,000 lbs. This may require strong pedestals and floor tiles; and
6. Cleaning the data center floors require much more attention, since there is the possibility of dust ingress and accumulation.

Raised floors are subject to local building codes and national and industry regulatory standards. Floor tiles should resist wear and abrasion and should contain conductive materials to help remove the buildup of damaging static electricity from the environment. The American Society of Heating, Refrigerating and Air Conditioning Engineers (ASHRAE) provide structural guidelines for raised floors that house cooling mechanisms.

### **HOT AISLE / COLD AISLE LAYOUT**

Hot aisle/cold aisle is a layout design for server racks and other computing equipment in a data center. In its simplest form, a hot aisle/cold aisle data center design involves lining up server racks in alternating rows with cold air intakes facing one way and hot air exhausts facing the other. The rows composed of rack fronts are called cold aisles and the rows at the rear are called hot aisles. The goal of a hot aisle/cold aisle configuration is to:

1. Avoid mixing hot and cold air before the air passes through the equipment;
2. Keep warm air away from IT inlets;
3. Move warm air towards the return system; and
4. Conserve energy and lower cooling costs by managing the air flow.

The key features are:

#### **Cold aisle**

- Racks are face to face;
- Perforated tiles (24" x 24") in the raised floor deliver cold air;
- Typically, cold aisles face air conditioner output ducts;
- Cold air is drawn into the face of the rack; and

- Aisles are typically two tiles wide (48 inches).

**Hot aisle**

- Racks are back to back;
- Heat is expelled out the back into hot aisle;
- Typically, hot aisles face air conditioner return ducts;
- No perforated tiles; and
- Minimum recommended hot aisle is 36” inches.

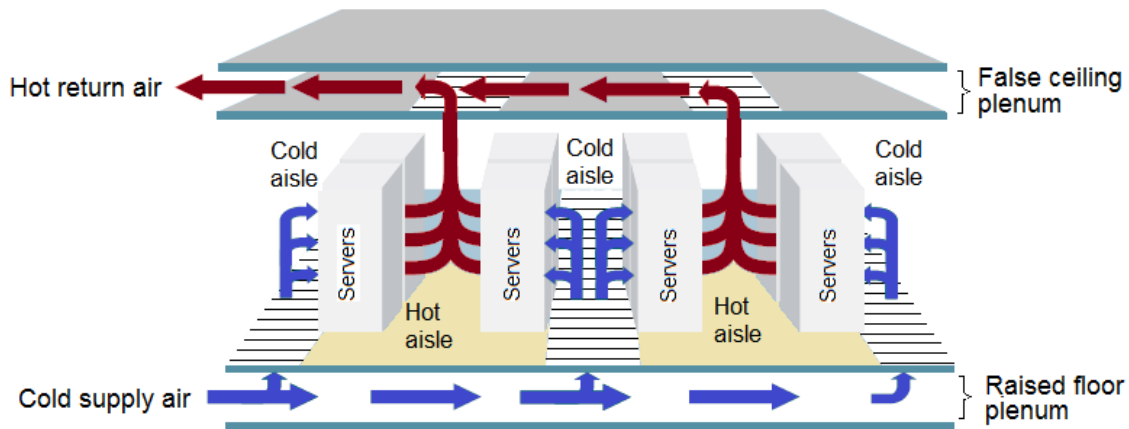

**Hot aisle- Cold aisle Layout**

The cold air supply for a raised-floor plenum environment can be through traditional air-handling units with ductwork routed into a floor plenum or precision air-conditioner units feeding to a cold aisle. Air outlets, such as perforated floor tiles, louvers and grates transfer air from a raised-floor plenum into a cold aisle. The amount of air delivered depends on the rating and design of an air outlet, as well as the static pressure. Raised-floor-plenum performance is dependent on the plenum's height, raised-floor leakage, plenum obstructions, and air distribution. Raised floors typically measure 18 inches to 24 inches from the building floor to the top of the tile. Floor tiles are usually 24 inches square and supported by a grounded grid structure. The main purpose of the plenum beneath the raised floor is to direct cool air to the racks.

Best practices for a hot aisle/cold aisle containment include:

1. Raising the floor 1.5 feet so that the air being pushed by the air conditioning equipment can pass through;
2. Deploying high cubic feet per minute (CFM) rack grills that have outputs in the range of 600 CFM;
3. Locating devices with side or top exhausts in their own part of the data center;  
and
4. Installing automatic doors in the data center.

**Important** - Note that the hot aisle/cold aisle configurations can be served by overhead or under-floor air distribution systems. The underfloor cooling is a better option. When an overhead system is used, supply outlets that 'dump' the air directly down should be used in place of traditional office diffusers that throw air laterally to the sides. Such diffusion can cause cool air to migrate undesirably into the return air path prior to having the opportunity to transfer heat from the equipment. The diffuser arrangement should match the facility equipment layout. It is imperative to align the supply air to the cold aisles and the return grilles to the hot aisles.

## **SECTION - 5            COOLING PERFORMANCE AND EFFICIENCY**

The typical power consumption trend in today's data centers is:

- 50% is consumed by the main hardware including servers, storage and networking equipment.
- The remaining 50% is consumed by auxiliary equipment including HVAC, UPS, power network, etc.

Cooling consumes more than 35% of which 15% is consumed solely by the refrigeration unit; the remaining 20% by the air distribution system. There are a number of basic things that can be done to enhance the energy efficiency of the cooling system. Here are few efficiency tips:

### **Efficiency Tip #1: Static pressure in the supply air plenum**

A critical component of the air conditioning system is the raised floor plenum. The plenum must provide a path for the chilled air to the perforated tile and/or cabinet. The ability of the floor plenum to perform this function depends on the local static pressure in the plenum below the perforated tile. Ideally, the static pressure in the plenum shall be at least 5 percent greater than the pressure above the floor. The placement of perforated floor tiles and their openings are major factors in maintaining static pressure. A 25% perforated tile provides ~500 CFM at a 0.05 in-wg static pressure, while a 50% perforated tile provides ~2000 CFM at a 0.05 in-wg static pressure. Complications can result from perforated floor tiles being positioned either too close or too far from the air handler units. Floor tiles placed too far will produce little to no airflow causing hot spots. The good practices include:

- The maximum distance to the outlet should be restricted to 30 feet from the air handling unit discharge.
- Fan-assisted diffusers should be used on the raised floor plenum to increase the supply air circulation. Fan-assisted diffusers can provide 200 to 2000 CFM of supply air.
- A more sophisticated method uses “Complex Fluid Dynamics (CFD)” analysis that provides detailed information about the movement of air, and the

temperature throughout a data center. This assists in the correct placement of data center equipment and cooling in a data hall. Currently, CFD analysis is challenging and expensive. It is most suitable for large data centers (over 1 MW), in which small increases in efficiency result in substantial savings.

- A FLIR camera can be useful in identifying the air temperature and movement. The camera captures small temperature gradients. This information can be used to find hot spots as the basis for efficiency improvements and removing faults.

**Efficiency Tip #2: Location of perforated tiles**

Perforated tiles should be installed in the cold aisles only and aligned with the intakes of the equipment. Perforated tiles should not be placed in the hot aisles no matter how uncomfortably hot aisles are. Hot aisle by design are supposed to be hot. Placement of open tiles in the hot aisles artificially decreases the return air temperature to the CRAC units, thereby reducing their efficiency and available capacity. This phenomenon contributes to hot spot problems in the data center.

**Efficiency Tip #3: Placement of CRAC units**

Location of CRAC units is crucial. A setup where CRAC's are positioned parallel to the rack rows results in mixing of hot and cold air, leading to insufficient cooling of the upper rack sections.

CRAC's should be placed perpendicular to the rows of equipment and aligned with the hot aisles. Airflow takes the path of the least resistance; meaning there is risk of a disproportionate amount of supply air delivered through the floor outlets as well as the risk of hot return air recirculating back into the cabinets. The CRAC's shall be positioned at the ends of the hot aisles; not aligned with the rack rows. This facilitates the shortest return of the hot air back to the CRAC and maximizes the static pressure to the cold aisle.

Rooms that are long and narrow are cooled effectively by placing CRAC's around the perimeter. Large square rooms may require CRAC's to be placed around the perimeter and also through the center of the room.



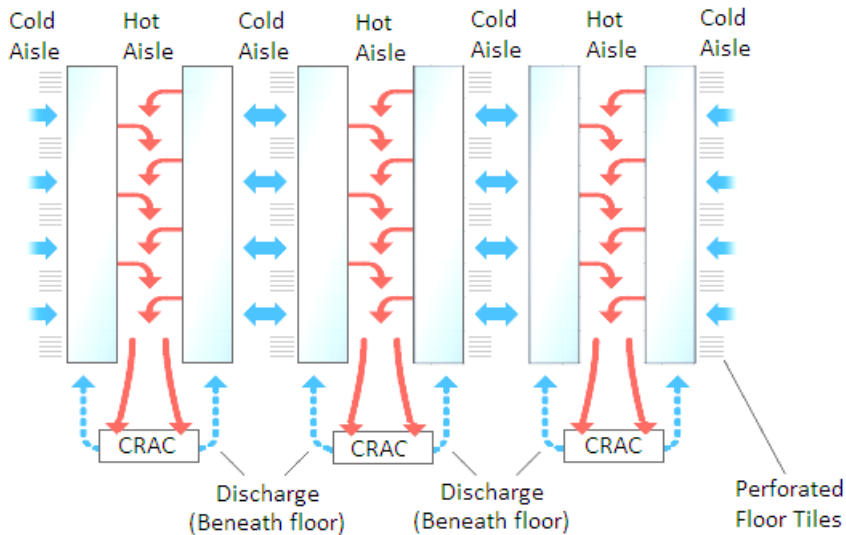

**Efficiency Tip #4: Return air**

Heat exchange is based upon the temperature differential between the return air and coil temperature. We emphasized in efficiency Tip #2 that cold aisles should be cold, hot aisles should be hot, with the intent to increase the return air temperature. A rise in return air temperature automatically involves a rise in the temperature of both supply air and room air.

To achieve an optimum airflow pattern, warm exhaust air must be returned to the AHU via ducts and the return air grilles shall be located directly above the top of the hot aisle/server racks. This provides a path for the rising hot air to escape into the return plenum without flowing horizontally across the room.

**Efficiency Tip #5: Cold aisle and hot aisle containment**

Even with a best designed hot aisle/cold aisle layout, the recirculation of air from IT equipment exhaust finds its way to the IT inlet or the cool air supply is bypassed directly to the return air stream. Both contribute to the reduction of server performance and driving down precision cooling efficiencies.

An effective strategy to deal with the problem is the use of a containment system to isolate hot aisles and cold aisles from each other and prevent hot and cold air from mixing. Use vinyl plastic sheeting or flexible clear-plastic barriers, such as supermarket

refrigeration covers, to seal the space between the tops of the racks and the ceiling, or air return location can control airflow while allowing flexibility in accessing, operating, and maintaining the computer equipment below.

The figure below shows cool air being supplied through an underfloor plenum to and through the racks, into a separated semi-sealed area for return to an overhead plenum. This approach uses a baffle panel or barrier above the top of the rack and at the ends of the cold aisles to eliminate “short-circuiting” (mixing of hot with cold air). These changes should reduce fan energy requirements by 20 to 25%, and could also save 20% of chiller energy.

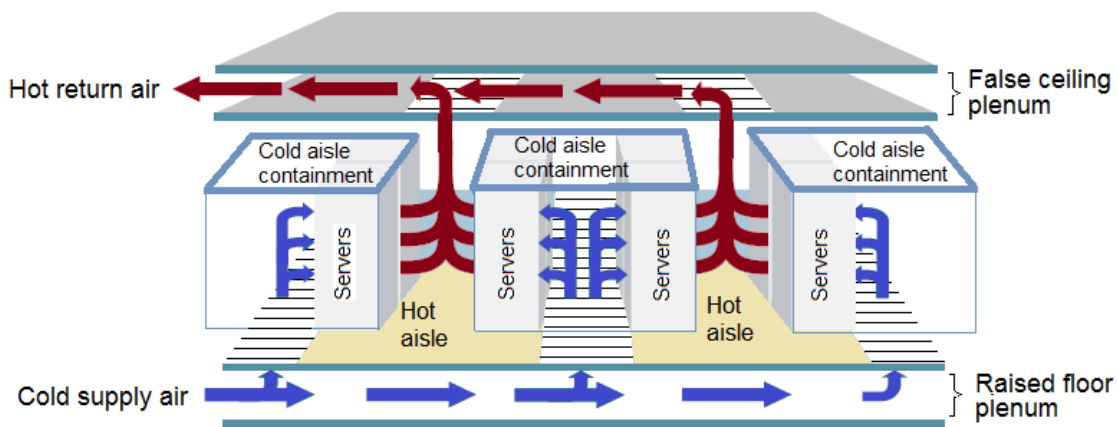

**Cold Aisle Containment**

Hot aisle containment is similarly done but containing both supply and return air streams is not recommended due to the extra costs without added benefits.

**Efficiency Tip #6: Cooling footprint**

The total physical space required for the data center includes the cooling footprint of all the racks plus the free space for aisles, ramps and air distribution. Typically, a width of at least two floor tiles (4 feet) is needed for cold and hot aisles to permit unobstructed access, equipment movement and maintenance.

A standard rule of thumb for an efficient layout is 25 cabinets per 1,000 square feet of a data center, which includes the area for cabinets, aisles, networking, power distribution, and air handling equipment. For example, if a cabinet is 2 feet wide and 4 feet deep, it

occupies 8 square feet. The cold aisle in front is 4 feet, shared between two rows of cabinets, so the portion dedicated to each cabinet is 8 divided by 2, or 4 square feet. The same calculation applies to the hot aisle behind each cabinet. In this example, the work cell dedicated to each cabinet is 16 square feet.

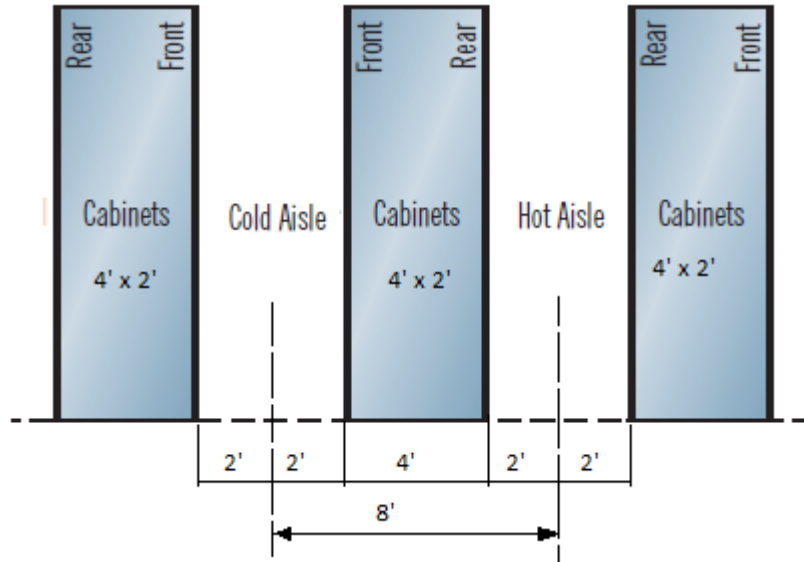

A well designed data center typically utilizes approximately 50 to 60% of the floor area for IT racks or cabinets and the remaining space for power/network cabling, cooling and general movement.

**Efficiency Tip #7: Reduce system resistance**

It is not unusual to find considerable amounts of cable trays, power wire-ways and ductwork in the cold aisle, which impede air circulation and adversely affect the air pressure conditions required for server cooling. As a result, the air conditioning system has to pump more cold air into the data center in order to achieve the required cooling level. All the gaps and openings in the raised plenum should be plugged to provide a tight seal. U-shaped “basket” cable trays or cable hangers can be used to manage cable paths, prevent blockage of airflow, and provide a path for future cable additions.

**Efficiency Tip #8: Maintaining room tightness**

The tighter the structure, the less outdoor air flow is needed to provide the desired room over-pressure, and therefore the less will be the operating costs. The worst leakage

areas are service holes and crackage in the structure; therefore, it is essential that they are kept to a minimum. These areas include:

- **Doors:** The number of doors must be kept to a minimum. Doors not in everyday use, like hauling and trap doors, should be securely sealed. It is recommended to use only one door in the room and carefully seal other exits. Doors in everyday use should have air locks to reduce uncontrollable airflow. Doors should be self-closing; essential fire doors must be fitted with tight seals.
- **Windows:** These should be avoided in data centers. It is difficult to seal window frames. In addition solar radiation through the windows increases the external heat gain to the room.
- **Structural Penetrations for Cables and Pipes:** The holes for cables and pipes in the walls of the room should be sealed carefully with an incombustible airtight material. Gypsum can be used for sealing but it can break down with movement.
- **Element Joints:** All the element joints have to be carefully sealed airtight before painting the walls. The expansion joints shall not be placed on the roof of the data center room. If an expansion joint has to be located in the room, it has to be carefully tightened.

**Efficiency Tip #9: High-efficiency refrigeration equipment**

Data centers offer a number of opportunities in central plant optimization, both in design and operation. Here are few tips:

- Use energy efficient star rated DX equipment for small and medium loads and water-cooled chillers for large loads.
- A high efficiency inverter compressor for a DX system and a VFD chiller with an appropriate condenser water reset is typically the most efficient cooling option for large facilities.
- Design for medium temperature chilled water (55°F) in lieu of low-temperature chiller (42°F). This eliminates uncontrolled dehumidification, improves chiller efficiency and reduces plant operating costs.

- Use water cooled condensers. Water always outperforms air although the size of the savings will vary from cold climates to hot climates and from arid to humid ones. Cooling towers with an approach of 5 to 7°F should be used and a reset implemented to maintain a condenser water temperature of 5-7°F above the ambient wet bulb temperature.
- Use high efficiency fans such as vane axial or mixed-flow fans.
- Keep motors out of airstreams and buy the most efficient motor on the market (Motor- Master Software from DOE shows no efficiency/price correlation up to at least 300 hp).
- Design hydronic loops to operate chillers near design temperature differential, typically achieved by using a variable flow evaporator design and staging controls.
- Design a low pressure drop pipe layout for pumps.
- Use a VFD to control the pump flow rate.

**Efficiency Tip #10: Free cooling**

The data centers require year round cooling, and the cooling demand is largely constant and remains unchanged irrespective of the varying seasons or day/night operation. When the outdoor temperature and humidity are mild, outside air can be introduced into the space for cooling in lieu of running chillers and compressors. Free cooling, sometimes called “air-side economization”, uses a system of modulating dampers that adjust to the external climatic conditions. When the outside ambient temperatures are low, say during night or during winter times, the damper control system allows cold outside air to enter the room without running the refrigeration compressor. When the outside ambient temperature rises, the air handling control system switches to cooling cycle.

**Note:** Free cooling doesn’t do away with the cooling infrastructure, but it does minimize its use. A cooling plant is still necessary to deal with the periods where the external air is too warm and where the external air is too humid and requires dehumidification.

### **Efficiency Tip #11: Thermal storage**

Thermal storage is a method of storing thermal energy in a reservoir for later use, and is an efficient method of increasing plant capacity without adding chillers. Thermal storage offers three main benefits:

1. First, it takes advantage of the off-peak electric rates which are typically significantly lower.
2. Second, chilled water systems operate more efficiently when the outside air temperatures are lower.
3. Third, chilled water storage adds redundancy and can often substitute for one or more back up chillers. It can be an economical alternative to additional mechanical cooling capacity.

Thermal storage is recommended predominantly to facilities larger than 10,000 sq. ft. Water storage is preferred over ice because water is simpler, cheaper and more reliable, although it requires more space. Use multiple tanks for system redundancy and emergency backup cooling potential.

### **Efficiency Tip #12: Efficient electrical systems**

One major source of electrical inefficiency is through transformers required to step-down the voltages at each individual device within the data center (usually a low voltage around 120V AC to 240V AC). Transformers lose power in the form of heat when voltage is being converted. The following are general guidelines for delivering electrical power in the most energy-efficient manner possible:

- Minimize the resistance by increasing the cross-sectional area of the conductors and making it as short as possible.
- Maintain a higher voltage for as long as possible to minimize the current.
- Use switch-mode transistors for power conditioning.
- Locate all voltage regulators close to the load to minimize distribution losses at lower voltages.

- Specify energy efficiency equipment. For example, a dry-type transformer with a 176°F temperature rise uses 13 to 21% less energy than a 302°F rise unit. In addition, operating a transformer at an optimized load factor (around 50%) will reduce the loss of power through the transformer.

**BENCHMARKING**

Data center cooling systems consume a large amount of energy. To facility operations and maintenance teams, the following metrics will provide an optimization opportunity and help in meeting the efficiency standards.

**HVAC System Effectiveness**

Power that enters a data center facility is divided into two components:

- IT equipment (servers for data storage, processing and applications)
- Supporting infrastructure (mainly HVAC).

HVAC system effectiveness is defined as the ratio of the annual IT equipment energy to the annual HVAC system energy:

$$\text{HVAC Effectiveness} = \frac{\text{kWh/yr}_{IT}}{\text{kWh/yr}_{HVAC}}$$

<b>Standard</b>	<b>Good</b>	<b>Better</b>
0.7	1.4	2.5

For a fixed value of IT equipment energy, a lower HVAC system effectiveness corresponds to a relatively high HVAC system energy use and, therefore, a high potential for improving HVAC system efficiency. Note that a low HVAC system effectiveness may indicate that server systems are far more optimized and efficient compared to the HVAC system. According to the database of data centers surveyed by Lawrence Berkeley National Laboratory, HVAC system effectiveness can range from 0.6 to 2.5.

**Airflow Efficiency**

This metric characterizes overall airflow efficiency in terms of the total fan power required per unit of airflow. This metric provides an overall measure of how efficiently air

is moved through the data center, from the supply to the return, and takes into account low pressure drop design as well as fan system efficiency.

$\frac{\text{Total Fan Power (W)}}{\text{Total Fan Airflow (CFM)}}$	<b>Standard</b> 1.25 W/cfm	<b>Good</b> 0.75 W/cfm	<b>Better</b> 0.5 W/cfm
---	-------------------------------	---------------------------	----------------------------

### Cooling System Efficiency

The most common metric used to measure the efficiency of an HVAC system is the ratio of the average cooling system power usage (kW) to the average data center cooling load (tons). A cooling system efficiency of 0.8 kW/ton is considered a good practice while an efficiency of 0.6 kW/ton is considered a better benchmark value.

$\frac{\text{Average Cooling System Power (kW)}}{\text{Average Cooling Load (ton)}}$	<b>Standard</b> 1.1 kW/ton	<b>Good</b> 0.75 kW/ton	<b>Better</b> 0.5 kW/ton
--	-------------------------------	----------------------------	-----------------------------

Effective metering of a data center should be implemented to accurately understand the inputs and outputs of the facility. A true-power kW sensor, which incorporates voltage, amperage and power factor measurements, should be selected to monitor HVAC power. Additional instrumentation should include the data center server temperature and humidity conditions on real time basis. Most modern HVAC systems offer a simple network management protocol (SNMP) agent that can be tied in to your monitoring system in the network operation center (NOC).

### Summary

Raised-floor plenums can be used effectively for high-heat-density-load applications. Many variables can influence the performance of a raised-floor plenum. The impact of each needs to be considered carefully, while a desired result (i.e., air-inlet temperature within the ASHRAE-recommended range for data centers) needs to be understood.

If planned and implemented with care, a hot aisle/cold aisle layout can dissipate heat loads of up to approximately 5 kW per rack. These figures are usually considerably lower in older data centers, between approximately 1 and 2 kW per rack, where cooling optimization features are not in place.



## **References**

- ASHRAE (The American Society of Heating, Refrigerating and Air-Conditioning Engineers): Thermal Guidelines for Data Processing Environments, 2nd Edition, 2009.
- Thermal Guidelines for Data Processing Environments, TC9.9 Mission Critical Facilities, ASHRAE, 2004.
- Thermal Guidelines for Data Processing Environments, TC9.9 Mission Critical Facilities, ASHRAE, 2004.
- Data Processing and Electronic Areas, Chapter 17. ASHRAE HVAC Applications, 2007.
- U.S. Environmental Protection Agency: Report to Congress on Server and Data Center Energy Efficiency, August 2007.
- Energy Star. Enterprise Server and Data Center Energy Efficiency Initiatives. <http://www.energystar.gov/datacenters>. Accessed December 3, 2009.
- The Green Data Center 2.0, Chapter 2, Energy-Efficient Server Technologies, 2009.
- U.S. Department of Energy, Energy Efficiency and Renewable Energy Industrial Technologies Program, Saving Energy in Data Centers. <http://www1.eere.energy.gov/industry/datacenters/index.html>. December 3, 2009.
- Self-Benchmarking Guide for Data Center Energy Performance Version 1.0, Ernest Orlando, Lawrence Berkeley National Laboratory, 2006.